



*Shindaiwa Generators*

# Owners Manual

## Sound Attenuated Diesel Generator Sets

**WARNING!**

**CALIFORNIA - Proposition 65 Warning**

Diesel engine exhaust and some of its constituents are known to the State of California to cause cancer, birth defects, and other reproductive harm.

**shindaiwa**  
*Construction Products*

## Table of Contents

<b>1. INTRODUCTION</b>	<b>4</b>
<b>2. SAFETY GUIDELINES</b>	<b>5</b>
<b>3. WARNING LABELS</b>	<b>7</b>
Label Locations DGK25A/DGK25B	8
Label Locations DGK45A, DGK60A, and DGK70B	9
Label Locations DGK45C	10
Label Locations DGK100B	11
<b>4. SPECIFICATIONS</b>	<b>12</b>
Model DGK25A/DGK25B	12
Model DGK45A	13
Model DGK45C	14
Model DGK60A	15
Model DGK70B	16
Model DGK100B	17
<b>5. OUTLINE DRAWINGS</b>	<b>18</b>
5.1 External View DGK25A/DGK25B	18
5.2 External View DGK45A/DGK60A	19
5.3 External View DGK45C	20
5.4 External View DGK70B	21
5.5 External View DGK100B	22
5.6 Control Panels	23
5.7 Main Terminal Board	25
5.8 Receptacle Panels	26
<b>6. EQUIPMENT</b>	<b>28</b>
6.1 Monitor Displays	28
Coolant Temperature Monitoring Lamp	28
Engine Oil Monitoring Lamp	29
Battery Charge Monitoring Lamp	29
6.2 Meters and Gauges	30
Hour Meter	30
Volt Meter	30
Ammeter	30
Frequency Meter	30
Coolant Temperature Gauge	30
Oil Pressure Gauge	30
Fuel Gauge	30
6.3 Lamps and Lights	31
Glow Lamp	31
Pilot Lamp	31
Panel Light	31
6.4 Switches	31
Start Switch	31
Voltmeter Selector Switch	32
Ammeter Selector Switch	32

Voltage Selector Switch-----	32
Panel Light Toggle Switch-----	32
Emergency Stop Switch -----	32
6.5 Output Circuit Breaker-----	33
6.6 Voltage Adjustment Knob-----	33
6.7 Three Way Fuel Valves-----	33
6.7.1 Using Fuel From The Internal Tank-----	33
6.7.2 Using Fuel From The External Fuel Tank -----	35
6.7.3 Three Way Valves Locations -----	36
<b>7. LIFTING, TRANSPORTING, AND INSTALLING-----</b>	<b>37</b>
7.1 Lifting -----	37
7.2 Transporting-----	37
7.3 Installing -----	38
<b>8. CONNECTING CABLES-----</b>	<b>39</b>
<b>9. INITIAL STARTUP AND PRE-CHECKS -----</b>	<b>43</b>
9.1 Checking Engine Oil -----	43
9.2 Selecting the Proper Engine Oil-----	44
9.3 Checking Engine Coolant -----	44
9.3.1 Checking Radiator Level/ Adding Coolant -----	45
9.3.2 Checking the Coolant Reservoir Tank Level/ Adding Coolant -----	45
9.4 Checking the Fan Belt-----	45
9.4.1 Tension -----	46
9.4.2 Condition-----	46
9.5 Checking the Fuel Level -----	46
9.6 Checking for Leaks-----	46
9.7 Checking the Battery -----	47
<b>10. OPERATION-----</b>	<b>48</b>
10.1 Starting -----	48
10.2 Loading the Generator-----	48
10.3 Operating the Generator -----	49
10.4 Stopping the Generator-----	49
10.5 Automatic Shutdowns -----	49
10.6 Connecting to an External Fuel Tank -----	50
<b>11. MAINTENANCE -----</b>	<b>51</b>
11.1 Oil Change-----	53
Frequency-----	53
Procedure -----	53
11.2 Oil Filter Change -----	53
Frequency-----	53
Procedure -----	53
11.3 Cleaning/Changing the Air Filter Element-----	53
Frequency-----	53
Procedure -----	53
11.4 Cleaning/Changing the Fuel Filter -----	54
Frequency-----	54
Procedure -----	54
11.5 Draining Water From the Internal Fuel Tank-----	54

Frequency .....	54
Procedure .....	54
11.6 Changing Engine Coolant .....	54
Frequency .....	54
Procedure .....	54

**12. LONG TERM STORAGE PROCEDURES .....** 55

**13. TROUBLESHOOTING .....** 56

# 1. Introduction

Thank you for purchasing a Shindaiwa Kwiet Power Sound Attenuated Diesel Generator.

- This user's manual was created to help ensure the safe operation of this equipment. The manufacturer of this equipment strongly recommends that the user follow all of the instructions contained within this manual to avoid unnecessary accidents or repairs.
- Operate this equipment only after thoroughly reviewing and understanding the contents of this manual.
- This manual should always be kept on or near the generator.
- The battery or batteries supplied with the generator are dry when shipped. Dilute sulfuric acid must be added.

The following convention will be used throughout this manual to indicate various degrees of cautions.

<b>▲ DANGER</b>	May cause severe injuries or death.
<b>▲ CAUTION</b>	May cause minor injuries or damage to the equipment or other property.
<b>CAUTION</b>	Other types of caution.

- Even some of the items noted in **▲ CAUTION** may lead to severe injuries. Read and carefully follow all items and safety guidelines.

## 2. Safety Guidelines

### **⚠ DANGER**

#### **Suffocation from exhaust fumes**

- Exhaust fumes from the engine on this diesel generating set contain many elements that have been proven to be harmful to humans. Do not operate this equipment in poorly ventilated areas such as inside a room or in a tunnel.
- Do not direct exhaust fumes toward people or buildings.

#### **Electrical Shock**

- Do not come in contact with or allow anything else to come in contact with the output terminals during operation.
- Be sure to place the protective covers over the output terminals and fasten them securely while operating this equipment.
- Do not insert metal objects (such as pins or wires) into plug-in receptacles.
- Do not touch the wiring or any electrical or electronic parts inside the equipment during operation.
- There is always a danger of being electrocuted by a short-circuit to ground. Be sure to test the generator's insulation resistance to ground periodically.
- Before connecting or disconnecting load cables from the output terminals, always turn the output circuit breaker to the OFF position, stop the engine, and remove the engine key. The person performing the cable disconnect should always keep the key.
- Before performing any equipment check or maintenance, stop the engine, and remove the engine key. The person performing the check or maintenance should always keep the key.

#### **Injuries**

- To avoid injuries by unintentional contact with the cooling fan or fan belt, close and lock all doors while operating this equipment.
- When lifting the equipment, always use the installed lifting hook. **The lifting hook is designed to lift only the generator. Do not lift any additional added weight such as fuel tanks and/or trailers.**

### **⚠ CAUTION**

#### **Injuries to eyes and skin**

- Battery fluid contains diluted sulfuric acid. Avoid contact with eyes, skin or clothing. If contact with the acid does occur, especially with the eyes, flush immediately with large volumes of water and contact a physician.

#### **Fire**

- This equipment uses diesel (a flammable liquid) as a fuel. When refueling, always stop the engine, and maintain an adequate distance from flames or spark producing devices. Always wait until the engine cools down before refueling.
- Always immediately wipe up any diesel fuel or engine oil that is spilled. Do not use this equipment if there are any leaks. Repair the equipment before further use.
- Temperatures around the muffler and exhaust piping can get extremely high. Keep any flammable items (such as fuel, gas, paint, etc.) away from these areas.

## **⚠ CAUTION**

- The battery may emit highly explosive gases. Never expose it to flames or spark producing devices.
- This equipment must be operated only on flat surfaces and at least 3 feet away from any obstructions (such as walls) that could hinder airflow.
- Do not connect the AC output to any indoor wiring without an approved disconnecting device between the generator and the building's electrical service.

### **Burns**

- To avoid sustaining burns from hot vapor, do not open the radiator cap while operating or immediately after stopping this equipment.
- Due to extremely high temperatures, do not touch the engine or muffler while operating or immediately after stopping the equipment.
- When checking or changing engine oil, always stop the engine, and wait until the engine cools down. Opening either the line to the oil gauge or the oil filler cap during operation may cause severe burns due to hot oil.

### **Injuries**

- Do not use the tie downs for lifting. They are not designed to hold the weight of the equipment and using them for lifting may cause the equipment to fall.
- Always place the equipment on a flat and stable surface to keep it from sliding.
- When starting the engine, disconnect the supplied load and set the output circuit breaker to the OFF position.
- Do not move the equipment during operation.
- When performing equipment checks and/or maintenance, always stop the engine.
- Do not operate this equipment if it is being modified or if any parts have been removed.



## **WARNING KEEP TERMINAL BLOCK FREE OF DUST AND MOISTURE AT ALL TIMES!!**

Always keep environmental contaminants such as dust and moisture from building up on the terminal block and generator control box or arcing from the terminals to the generator control box or terminal block mounting screws may result.

### 3. Warning Labels

Caution, Danger, Warning and Operation Information Labels: Make sure all information labels are undamaged and readable. Immediately replace damaged or missing information labels. New labels are available from your local authorized Shindaiwa distributor or dealer.

Type	Location (s)	Part Number
Danger - Injury	Adjacent to each tie down on the enclosure top. <b>Text:</b> Do not lift this equipment with this tie down.	19402-00207
Caution – Potential Property Damage	Directly above the fuel drain plug on the enclosure panel. <b>Text:</b> Never remove fuel drain plug without proper containment and disposal method for fuel.	19402-00208
Caution – Potential Property Damage	Near or on the voltage selector switch. <b>Text:</b> Do not change voltage switch while the generator is running.	19402-00209
Danger - Injury	On each side of the lifting hook on the enclosure top. <b>Text:</b> Lifting hook designed to lift only the generator. Do not lift any additional added weight such as fuel tanks and/or trailers with this lifting hook.	19402-00210
Caution - Fire	Directly under the fuel fill cover. On the back enclosure panel on the DGK25B, on the left rear enclosure panel on the DGK45A, DGK60A and DGK100B, and on the right rear enclosure panel on the DGK45C. <b>Text:</b> Stop the engine and maintain an adequate distance from flames or spark producing devices while refueling. Allow the engine to cool down before refueling.	19402-00211
Danger - Poisoning	On the control panel door directly under the access handle or on the top right on the DGK45C. <b>Text:</b> Do not operate this equipment without adequate ventilation.	19402-00212
Danger - Injury	On the engine compartment access door. <b>Text:</b> To avoid accidental contact with moving parts, close and lock all doors while operating this equipment.	19402-00213
Caution – Burns	On the engine compartment access door and near the radiator fill cap access door on the enclosure top. <b>Text:</b> Do not come in contact with this area while the engine is operating or immediately after engine operation.	19402-00214
Danger – Electric Shock	On the output terminal access door and near the output terminals. <b>Text:</b> Do not come in contact with the output terminals while this equipment is operating. Turn the main circuit breaker to off and stop the engine before servicing.	19402-00215
Caution - Burns	Near the radiator fill cap access door on the enclosure top. <b>Text:</b> Do not open the radiator cap while operating or immediately after stopping this equipment.	19402-00216
Instructional	Immediately above the fuel fill cover. <b>Text:</b> Diesel Fuel (ASTM No. 2-D)	19401-00251

### Label Locations DGK25A/DGK25B

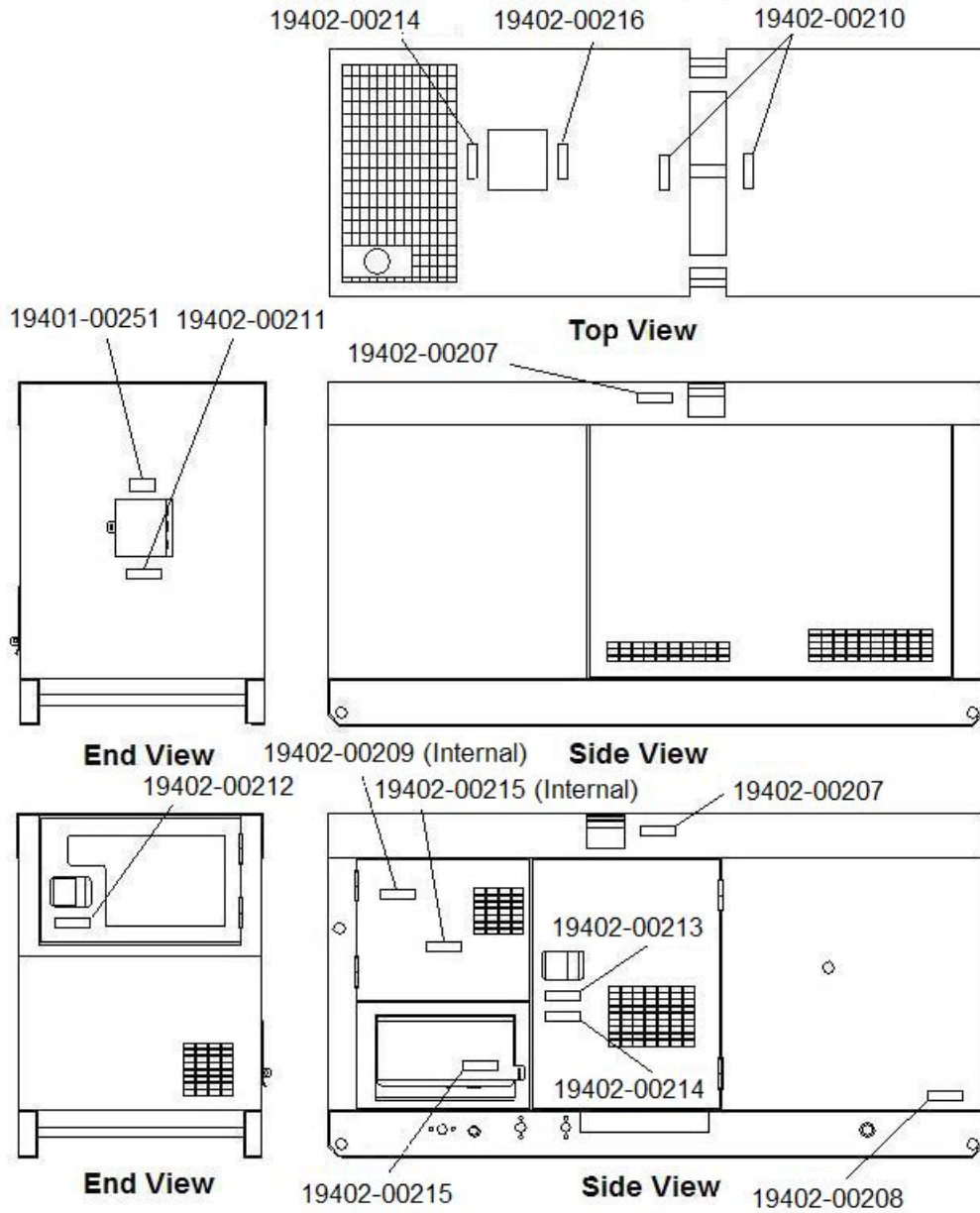

### Label Locations DGK45A, DGK60A, and DGK70B

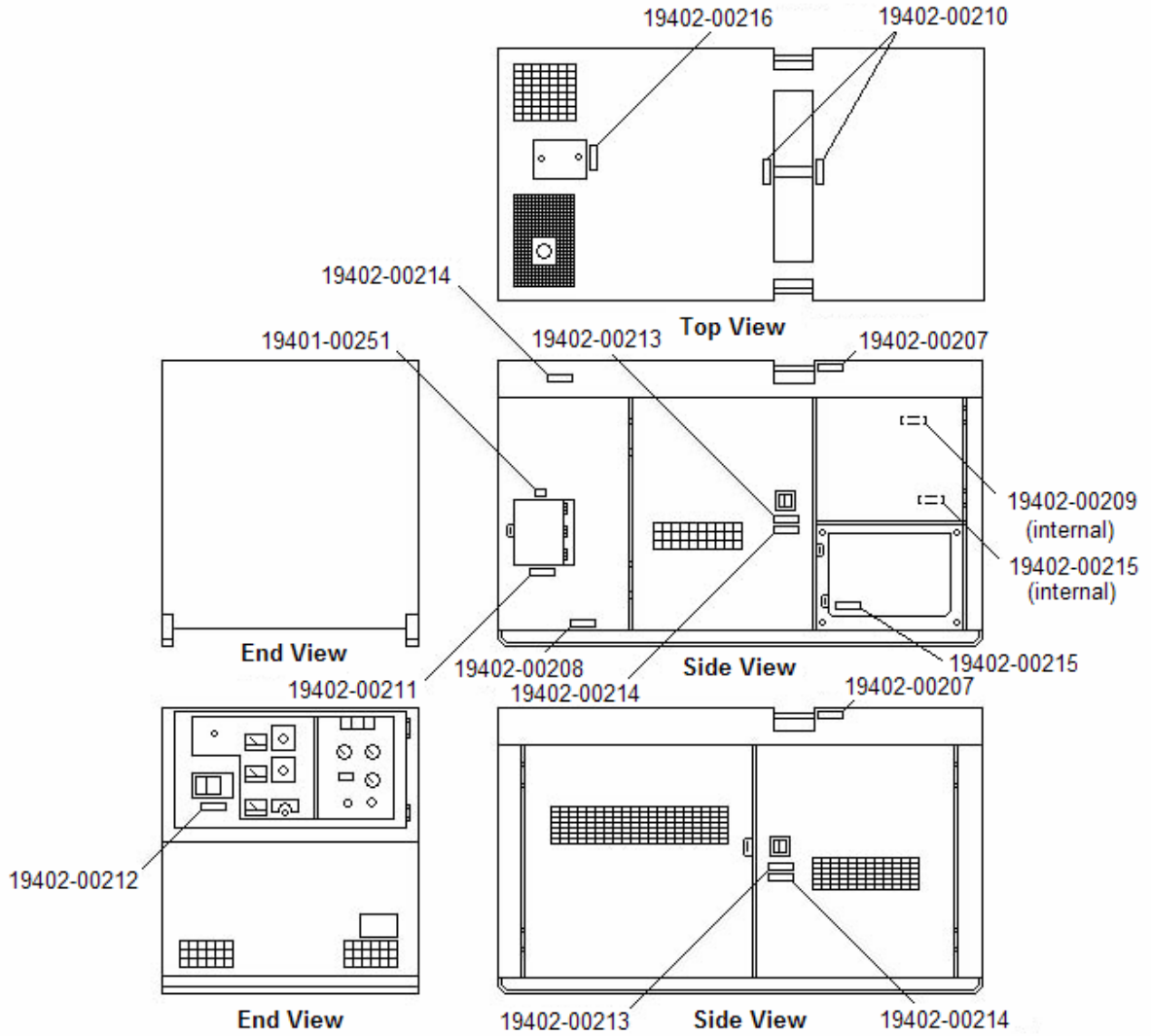

**Label Locations DGK45C**

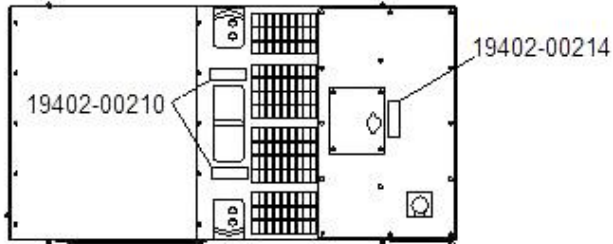

**Top View**

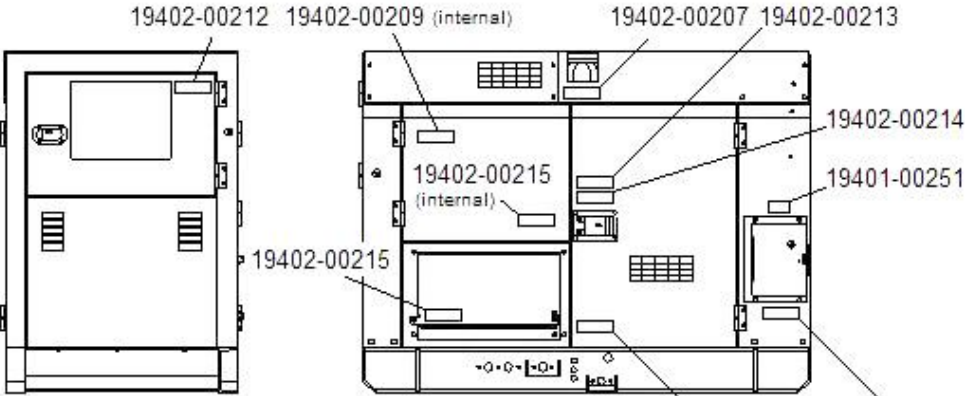

**End View**

**Side View**

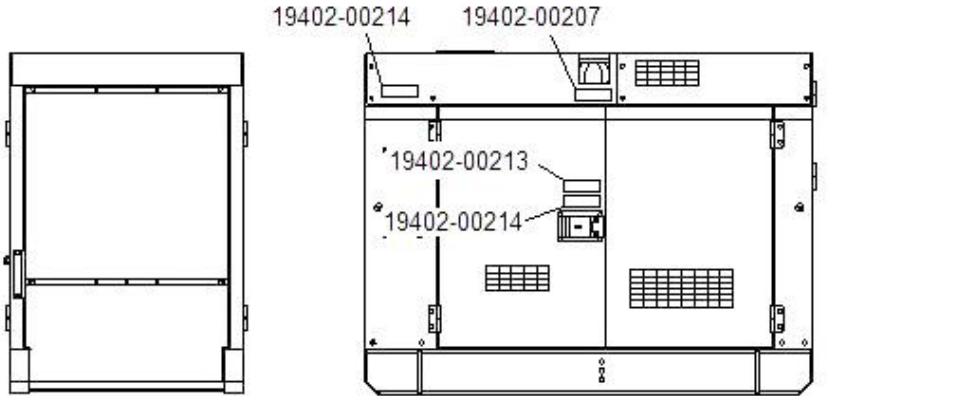

**End View**

**Side View**

## Label Locations DGK100B

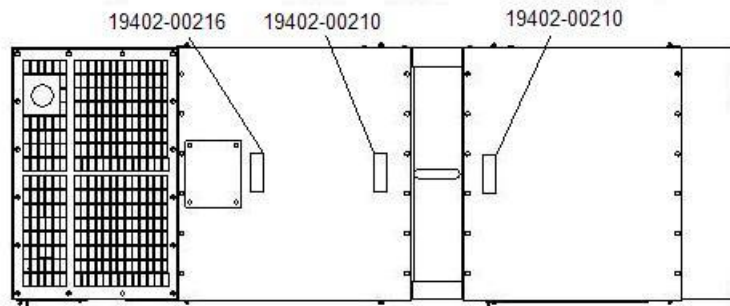

**Top View**

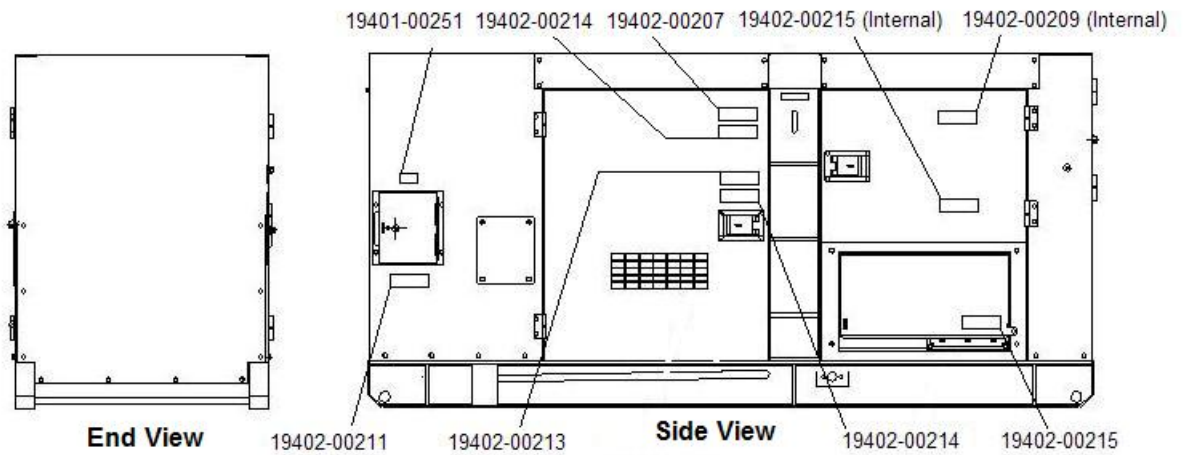

**End View**

**Side View**

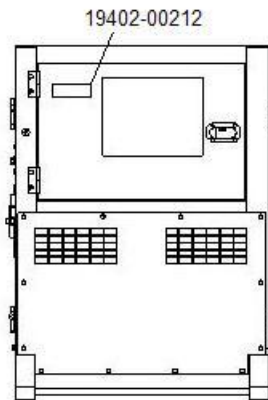

**End View**

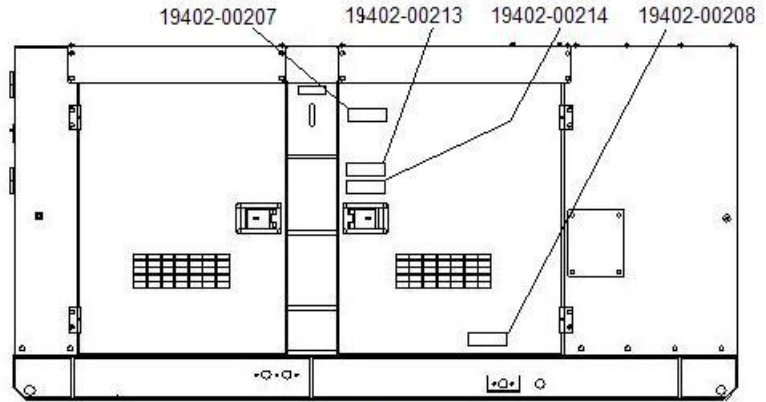

**Side View**

## 4. Specifications

<b>Model DGK25A/DGK25B</b>					
<b>Alternator</b>	Generator Type		Revolving Field Brushless AC		
	Rated Output	kVA	25		
		kW	20		
	Voltage – Three phase		V	240, 480	
	Voltage – Single phase		V	120, 240, 277	
	Amps	Single phase - 120V		A	55 (4-wire); 62 X 2 (Zig Zag)
		Single phase - 240V		A	27 (4-wire); 62 (Zig Zag)
		Three phase – 208V		A	60
		Three phase - 240V		A	60
		Three phase - 480V		A	30
	Frequency		Hz	60	
	Rated speed		rpm	1800	
	Winding			3-phase, 4-wire Star with neutral / Zig-zag	
	Power factor			.8	
Insulation class			F		
Excitation			Static excitation (brushless)		
No. of poles			4		
<b>Engine</b>	Type		Vertical Water-cooled 4-cycle Diesel Engine		
	Model (Manufacturer)		4LE1 (ISUZU)		
	No. of Cylinders (bore x stroke)		(in./mm)	4 (3.35 x 3.78/85 x 96)	
	Continuous rated output		hp	31	
	Rated speed		rpm	1800	
	Displacement		cu. in./liters	133/2.179	
	Combustion system			Swirl chambered	
	Cooling method			Radiator	
	Lubricating method			Forced lubrication	
	Starting method			Electric	
	Fuel			Diesel	
	Lubricating oil			CC class or higher	
	Fuel tank capacity		gal./liters	17.2/65	
	Lubricant volume		gal./liters	2.2/8	
	Cooling water volume		gal./liters	2.3/8.6	
	Starting motor capacity		V-kW	12V-1, 8kW	
	Charging alternator capacity		V-A	12V-20A	
Battery capacity		V-AH	12V-70AH		
<b>Meters</b>	Voltage/Frequency/Amperage/Hour				
<b>Voltage Regulation</b>	Automatic Voltage Regulator				
<b>Shutdowns</b>	Oil pressure, Water temperature		Lamp indication with shutdown		
<b>Warning</b>	Battery charge		Lamp indication		
<b>Unit</b>	Dimensions (L x W x H)		in./mm	68.9 x 25.6 x 36/1750 x 650 x 915	
	Dry weight		lbs./kg	1360/617	

<b>Model DGK45A</b>				
<b>Alternator</b>	Generator Type		Revolving Field Brushless AC	
	Rated Output		kVA 45 kW 36	
	Voltage – Three phase		V 240, 480	
	Voltage – Single phase		V 120, 240, 277	
	Amps	Single phase - 120V		A 100 (4-wire); 112 X 2 (Zig-Zag)
		Single phase - 240V		A 50 (4-wire); 112 (Zig Zag)
		Three phase – 208V		A 108
		Three phase - 240V		A 108
		Three phase - 480V		A 54
	Frequency		Hz 60	
	Rated speed		rpm 1800	
	Winding		3-phase, 4-wire Star with neutral / Zig-zag	
	Power factor		.8	
	Insulation class		F	
Excitation		Static excitation (brushless)		
No. of poles		4		
<b>Engine</b>	Type		Vertical Water-cooled 4cycle Diesel Engine	
	Model (Manufacturer)		4BG1 (ISUZU)	
	No. of Cylinders (bore x stroke)		(in./mm) 4 (4.13 x 4.92/105 x 125)	
	Continuous rated output		hp 56	
	Rated speed		rpm 1800	
	Displacement		<b>Cu .in./liters</b> <b>264.2/4.329</b>	
	Combustion system		Direct Fuel Injection	
	Cooling method		Radiator	
	Lubricating method		Forced lubrication	
	Starting method		Electric	
	Fuel		Diesel	
	Lubricating oil		CC class or higher	
	Fuel tank capacity		<b>gal./liters</b> <b>26.4/100</b>	
	Lubricant volume		<b>gal./liters</b> <b>3.8/14.02</b>	
	Cooling water volume		<b>gal./liters</b> <b>7.1/27</b>	
	Starting motor capacity		V-kW 24V-1, 4.5 kW	
Charging alternator capacity		V-A 24V-20A		
Battery capacity		V-AH 12V (2) -80AH		
<b>Meters</b>	Voltage/Frequency/Amperage/Hour			
<b>Voltage Regulation</b>	Automatic Voltage Regulator			
<b>Shutdowns</b>	Oil pressure, Water temperature		Lamp indication with shutdown	
<b>Warning</b>	Battery charge		Lamp indication	
<b>Unit</b>	Dimensions (L x W x H)		<b>in./mm</b> <b>74x34.6x48.8/1880x880x1240</b>	
	Dry weight		<b>lbs./kg</b> <b>2544/1154</b>	

<b>Model DGK45C</b>				
<b>Alternator</b>	Generator Type		Revolving Field Brushless AC	
	Rated Output		kVA 45	
			kW 36	
	Voltage – Three phase		V 240, 480	
	Voltage – Single phase		V 120, 240, 277	
	Amps	Single phase - 120V		A 225 (4-wire)
		Single phase - 240V		A 112.5 (4-wire)
		Three phase - 240V		A 108.3
		Three phase - 480V		A 54.1
	Frequency		Hz 60	
	Rated speed		rpm 1800	
	Winding		3-phase, 4-wire Star with neutral / Zig-zag	
	Power factor		.8	
	Insulation class		F	
Excitation		Static excitation (brushless)		
No. of poles		4		
<b>Engine</b>	Type		Vertical Water-cooled 4cycle Diesel Engine	
	Model (Manufacturer)		4JG1T (ISUZU)	
	No. of Cylinders (bore x stroke)		<b>(in./mm)</b> 4 <b>(3.75 x 4.21/95.4 x 107)</b>	
	Continuous rated output		hp 57	
	Rated speed		rpm 1800	
	Displacement		<b>Cu .in./liters</b> <b>186.7/3.059</b>	
	Combustion system		Direct Fuel Injection	
	Cooling method		Radiator	
	Lubricating method		Forced lubrication	
	Starting method		Electric	
	Fuel		Diesel	
	Lubricant oil		CC class or higher	
	Fuel tank capacity		<b>gal./liters</b> <b>32.8/124</b>	
	Lubricant volume		<b>gal./liters</b> <b>2.6/10</b>	
	Cooling water volume		<b>gal./liters</b> <b>3.4/13</b>	
	Starting motor capacity		V-kW 12V, 2.2 kW	
	Charging alternator capacity		V-A 12V-50A	
Battery capacity		V-AH 12V-80AH		
<b>Meters</b>	Voltage/Frequency/Amperage/Hour			
<b>Voltage Regulation</b>	Automatic Voltage Regulator			
<b>Shutdowns</b>	Oil pressure, Water temperature		Lamp indication with shutdown	
<b>Warning</b>	Battery charge		Lamp indication	
<b>Unit</b>	Dimensions (L x W x H)		<b>in./mm</b> <b>69.7x36.2x53.1/1770x920x1350</b>	
	Dry weight		<b>lbs./kg</b> <b>2513/1140</b>	

<b>Model DGK60A</b>				
<b>Alternator</b>	Generator Type		Revolving Field Brushless AC	
	Rated Output		kVA 60	
			kW 48	
	Voltage – Three phase		V 240, 480	
	Voltage – Single phase		V 120, 240, 277	
	Amps	Single phase - 120V		A 133(4-wire);150 X 2 (Zig Zag)
		Single phase - 240V		A 66 (4-wire); 150 (Zig Zag)
		Three phase – 208V		A 144
		Three phase - 240V		A 144
		Three phase - 480V		A 72
	Frequency		Hz 60	
	Rated speed		rpm 1800	
	Winding		3-phase, 4-wire Star with neutral / Zig-zag	
	Power factor		.8	
Insulation class		F		
Excitation		Static excitation (brushless)		
No. of poles		4		
<b>Engine</b>	Type		Vertical Water-cooled 4-cycle Diesel Engine	
	Model (Manufacturer)		4BG1T (ISUZU)	
	No. of Cylinders (bore x stroke)		(in./mm) 4 (3.35 x 3.78/85 x 96)	
	Continuous rated output		hp 78	
	Rated speed		rpm 1800	
	Displacement		cu in./liters 133/2.179	
	Combustion system		Direct Injection, Turbocharger	
	Cooling method		Radiator	
	Lubricating method		Forced lubrication	
	Starting method		Electric	
	Fuel		Diesel (ASTM No. 2-D)	
	Lubricating oil		CD class or higher	
	Fuel tank capacity		gal./liters 33/125	
	Lubricant volume		gal./liters 3.8/14.2	
	Cooling water volume		gal./liters 7.1/27	
	Starting motor capacity		V-kW 24V-1, 4.5 kW	
	Charging alternator capacity		V-A 24V-20A	
Battery capacity		V-AH 12V (2) -80AH		
<b>Meters</b>	Voltage/Frequency/Amperage/Hour			
<b>Voltage Regulation</b>	Automatic Voltage Regulator			
<b>Shutdowns</b>	Oil pressure, Water temperature		Lamp indication with shutdown	
<b>Warning</b>	Battery charge		Lamp indication	
<b>Unit</b>	Dimensions (L x W x H)		in./mm 78.3x34.6x48.8/1990x880x1240	
	Dry weight		lbs./kg 2681/1216	

<b>Model DGK70B</b>				
<b>Alternator</b>	Generator Type		Revolving Field Brushless AC	
	Rated Output		kVA 70	
			kW 56	
	Voltage – Three phase		V 240, 480	
	Voltage – Single phase		V 120,139, 240, 277	
	Amps	Single phase - 120V		A 155.5 (4 wire), 168x2(Zig-zag)
		Single phase - 240V		A 77.8 (4 wire), 168(Zig-zag)
		Three phase - 240V		A 168
		Three phase - 480V		A 84
	Frequency		Hz 60	
	Rated speed		rpm 1800	
	Winding		3-phase, 4-wire Star with neutral / Zig-zag	
	Power factor		.8	
	Insulation class		H	
Excitation		Static excitation (brushless)		
No. of poles		4		
Motor Starting Capability		sKVA XXX sKVA (30% Voltage Drop)		
<b>Engine</b>	Type		Vertical Water-cooled 4cycle Diesel Engine	
	Model (Manufacturer)		4BG1T (ISUZU) EPA2	
	No. of Cylinders (bore x stroke)		(in./mm) 4 (4.13 x 4.92/105 x 125)	
	Continuous rated output		hp 82	
	Rated speed		rpm 1800	
	Displacement		<b>Cu .in./liters</b> <b>264.2/4.329</b>	
	Combustion system		Direct Fuel Injection, Turbo Charger	
	Cooling method		Radiator	
	Lubricating method		Forced lubrication	
	Starting method		Electric	
	Fuel		Diesel	
	Lubricant oil		CD class or higher	
	Fuel tank capacity		<b>gal./liters</b> <b>33/125</b>	
	Fuel Consumption	Full Load	<b>gal./liters</b> <b>4.39/16.6</b>	
		75%	<b>gal./liters</b> <b>3.33/12.6</b>	
		50%	<b>gal./liters</b> <b>2.38/9.0</b>	
		25%	<b>gal./liters</b> <b>1.51/125</b>	
	Lubricant volume		<b>gal./liters</b> <b>3.8/5.7</b>	
	Cooling water volume		<b>gal./liters</b> <b>4.5/17</b>	
	Starting motor capacity		V-kW 12V, 2.5 kW	
Charging alternator capacity		V-A 12V-60A		
Battery capacity		V-AH 12V-80AH		
<b>Meters</b>	Voltage/Frequency/Amperage/Hour			
<b>Voltage Regulation</b>	Automatic Voltage Regulator			
<b>Shutdowns</b>	Oil pressure, Water temperature		Lamp indication with shutdown	
<b>Warning</b>	Battery charge		Lamp indication	
<b>Unit</b>	Dimensions (L x W x H)		<b>in./mm</b> <b>82.3x34.6x48.8/2090x880x1240</b>	
	Dry weight		<b>lbs./kg</b> <b>2745/1245</b>	

<b>Model DGK100B</b>					
<b>Alternator</b>	Generator Type		Revolving Field Brushless AC		
	Rated Output		kVA	100	
			kW	80	
	Voltage – Three phase		V	240, 480	
	Voltage – Single phase		V	120, 240, 277	
	Amps	Single phase - 120V		A	214 (4 Wire); 241 X 2 (zig zag)
		Single phase - 240V		A	107(4 Wire); 241 (zig zag)
		Three phase – 208V		A	241
		Three phase - 240V		A	241
		Three phase - 480V		A	120
	Frequency		Hz	60	
	Rated speed		rpm	1800	
	Winding			3-phase, 4-wire Star with neutral / Zig-zag	
	Power factor			.8	
Insulation class			F		
Excitation			Static excitation (brushless)		
No. of poles			4		
<b>Engine</b>	Type		Vertical Water-cooled 4-cycle Diesel Engine		
	Model (Manufacturer)		6BG1TC (ISUZU)		
	No. of Cylinders (bore x stroke)		(in./mm)	6/(4.13 x 4.92/105 x 125)	
	Continuous rated output		hp	150.2	
	Rated speed		rpm	1800	
	Displacement		cu	396.3/6.494	
			in./liters		
	Combustion system			Direct Injection, Turbo Charged, Inter Cooled	
	Cooling method			Radiator	
	Lubricating method			Forced lubrication	
	Starting method			Electric	
	Fuel			Diesel (ASTM No. 2-D)	
	Lubricant oil			CC class or higher	
	Fuel tank capacity		gal./liters	57.9/219	
	Lubricating volume		gal./liters	2.2/8	
	Cooling water volume		gal./liters	5.6/21.3	
Starting motor capacity		V-kW	12V, 4.5kW		
Charging alternator capacity		V-A	24V-30A		
Battery capacity		V-AH	12V(2)-80AH		
<b>Meters</b>	Voltage/Frequency/Amperage/Hour				
<b>Voltage Regulation</b>	Automatic Voltage Regulator				
<b>Shutdowns</b>	Oil pressure, Water temperature		Lamp indication with shutdown		
<b>Warning</b>	Battery charge		Lamp indication		
<b>Unit</b>	Dimensions (L x W x H)		in./mm	113x39.4x55.1/2870x1000x1400	
	Dry weight		lbs./kg	4079/1850	

## 5. Outline Drawings

### 5.1 External View DGK25A/DGK25B

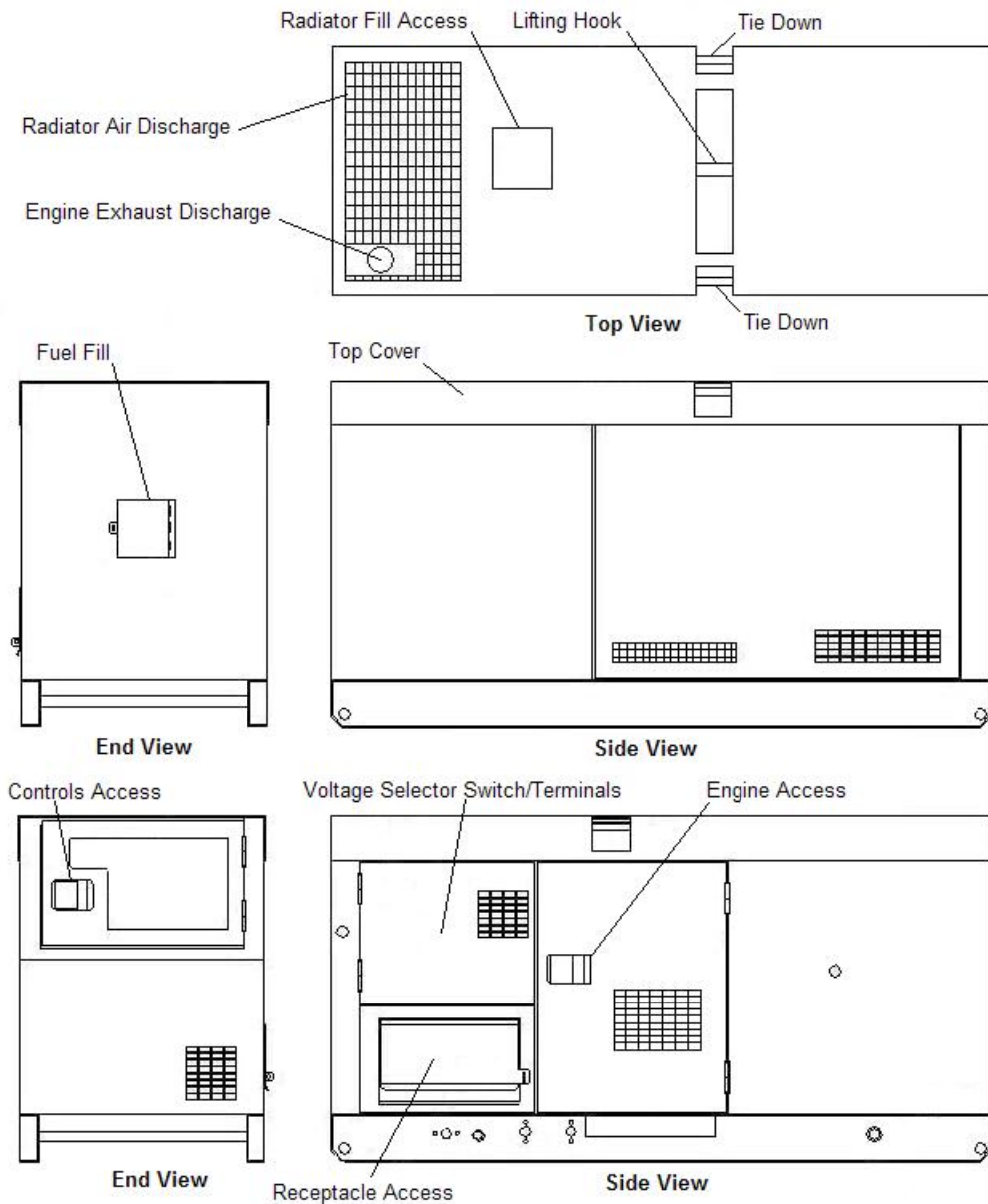

## 5.2 External View DGK45A/DGK60A

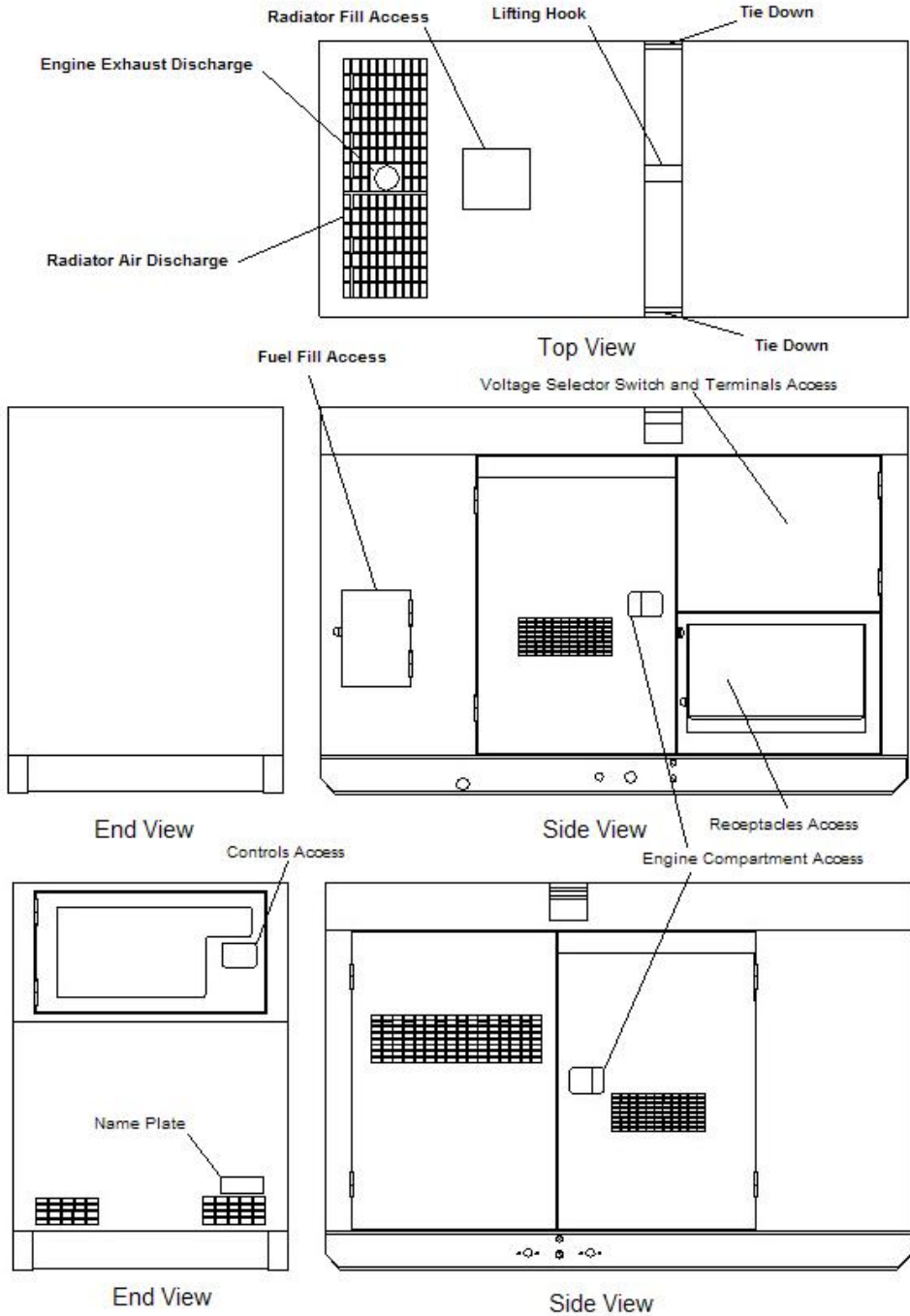

### 5.3 External View DGK45C

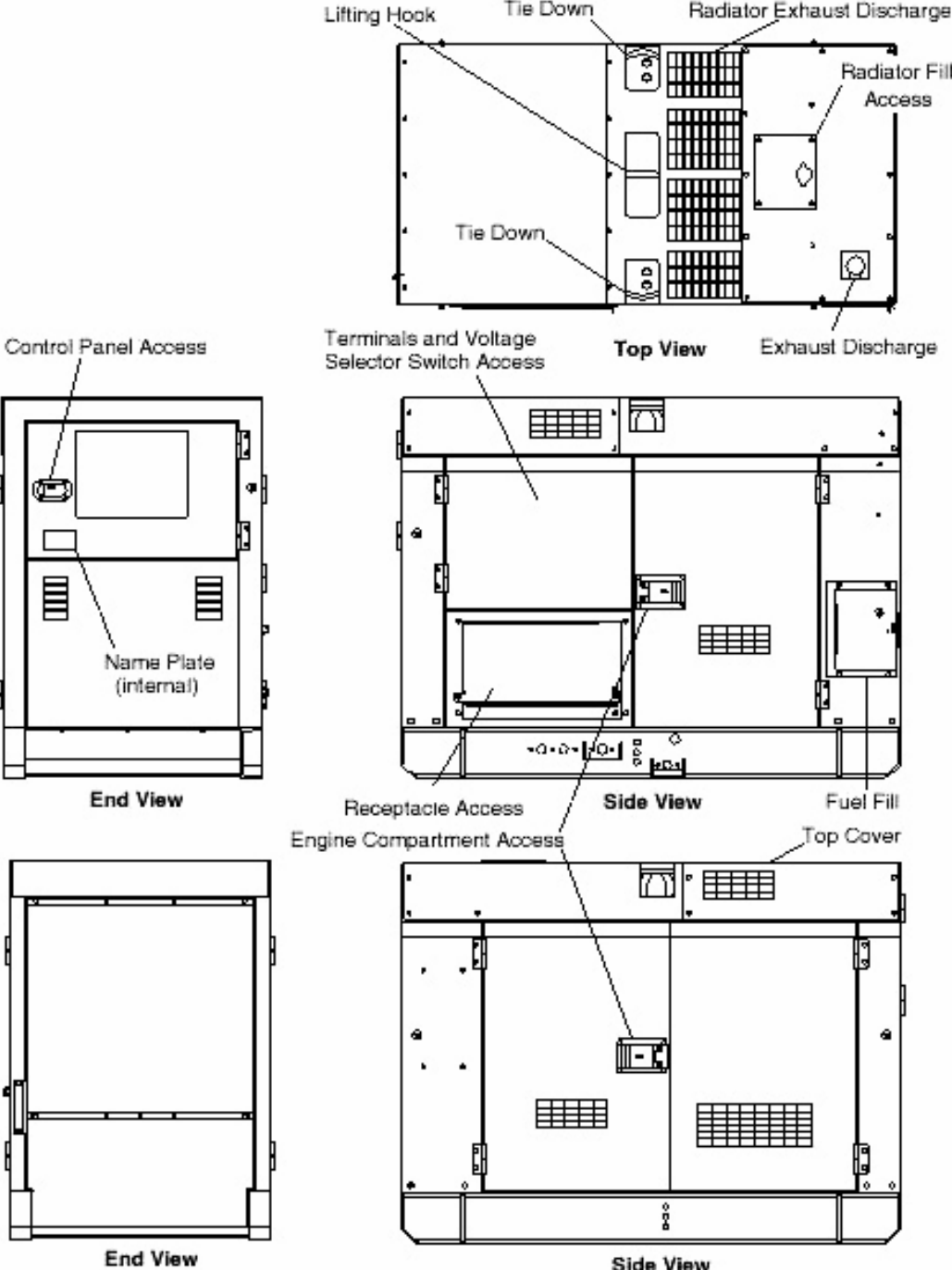

## 5.4 External View DGK70B

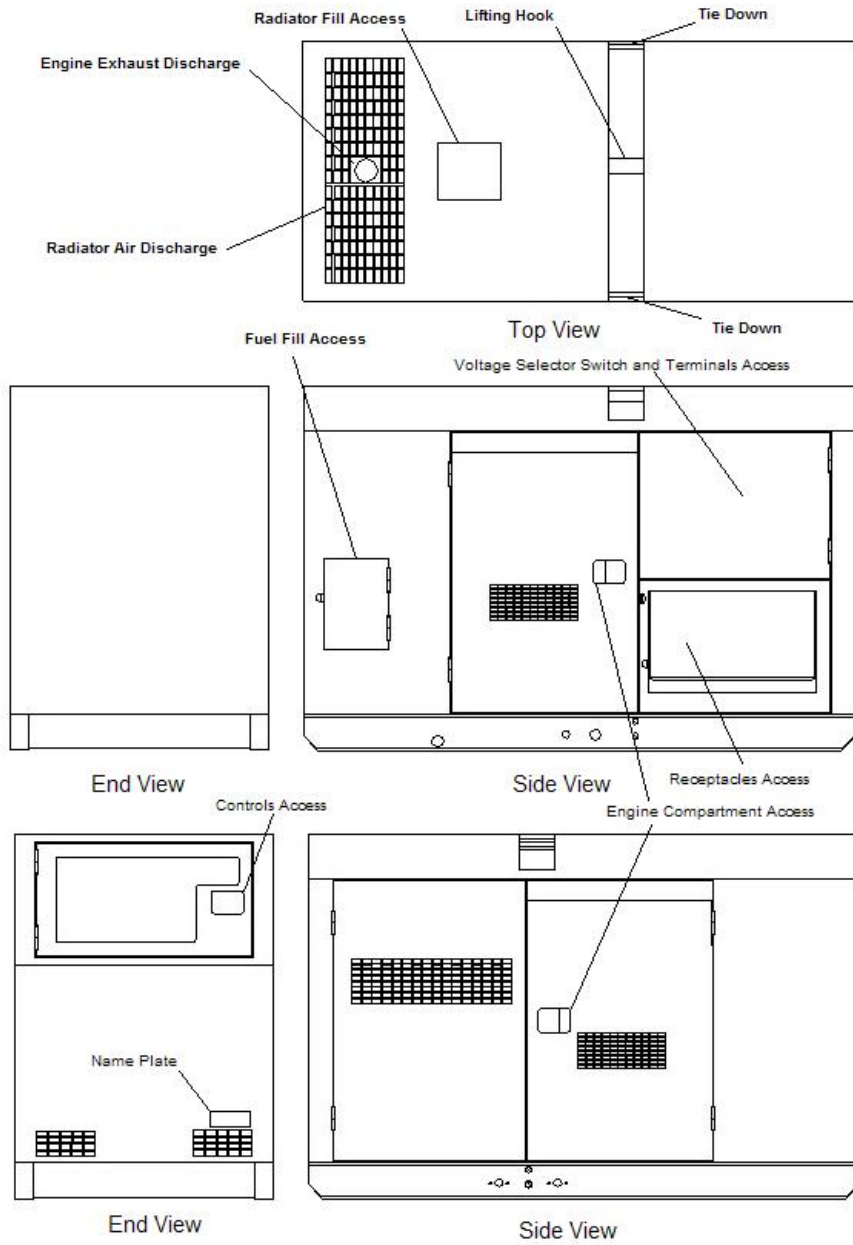

## 5.5 External View DGK100B

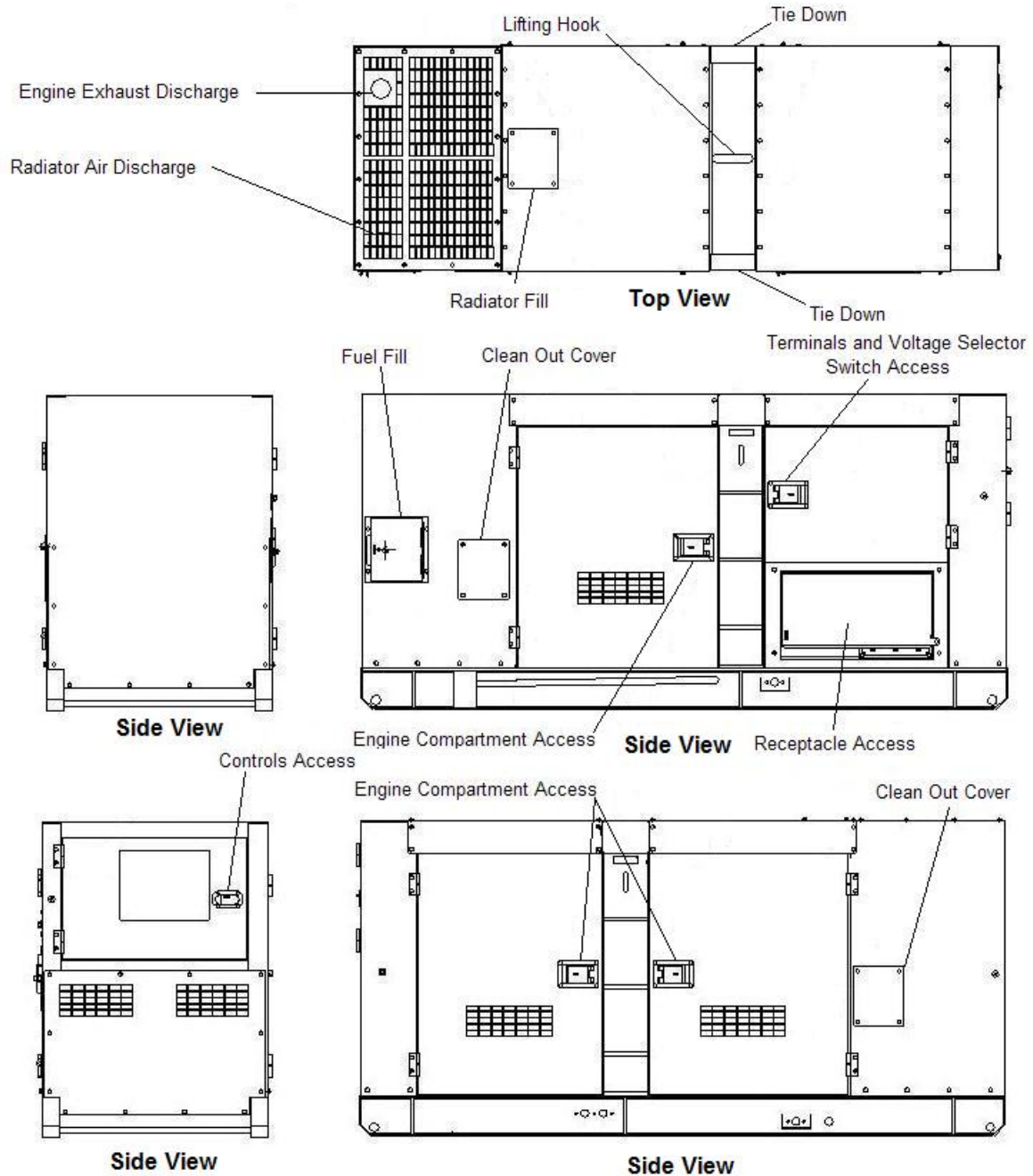

## 5.6 Control Panels

### DGK25A and DGK25B

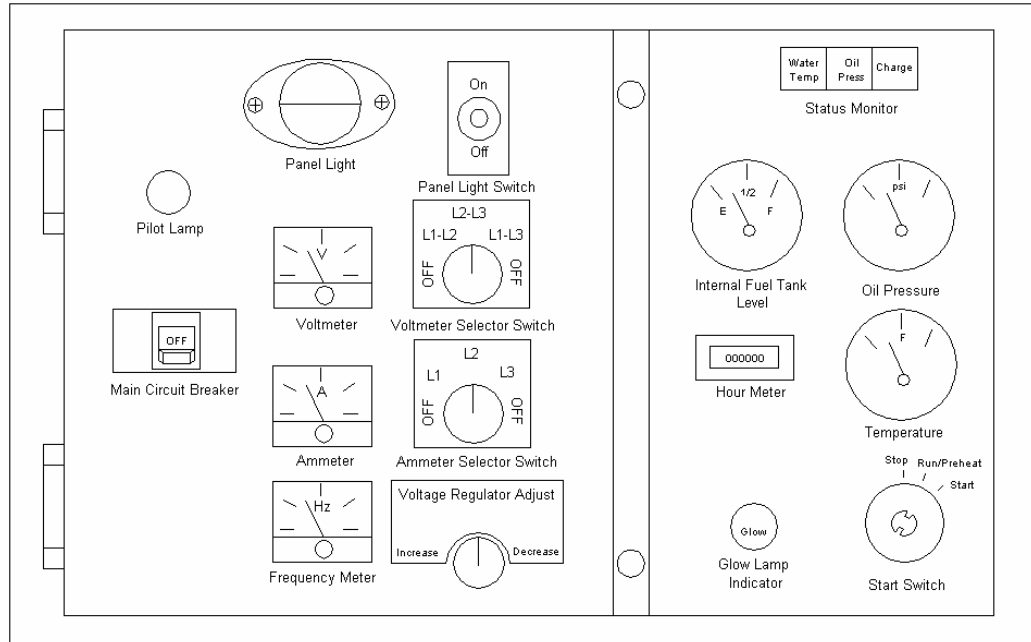

### DGK45A, DGK60A and DGK70B

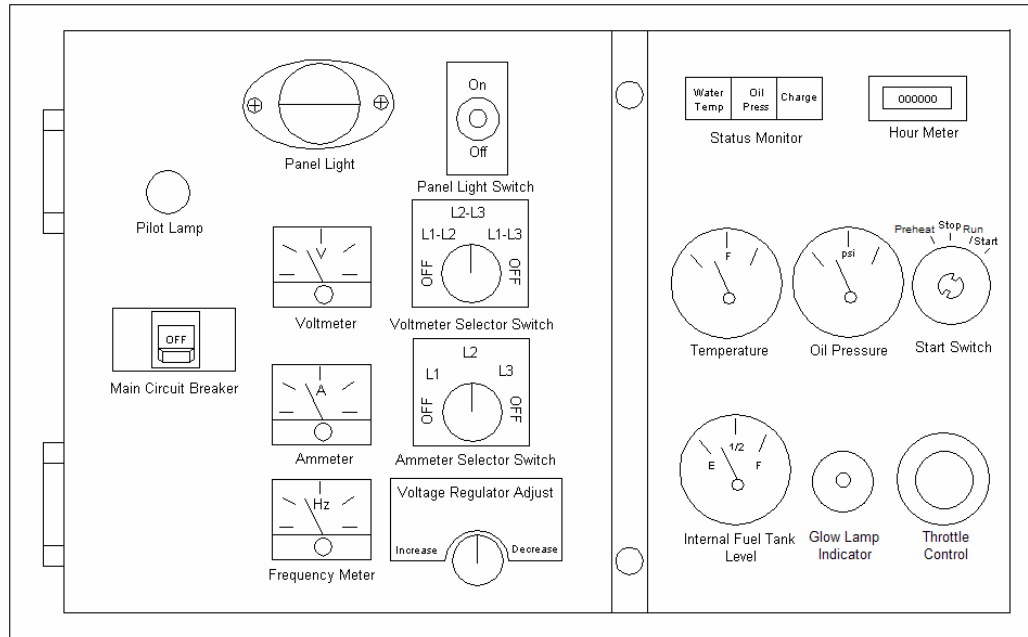

### DGK45C

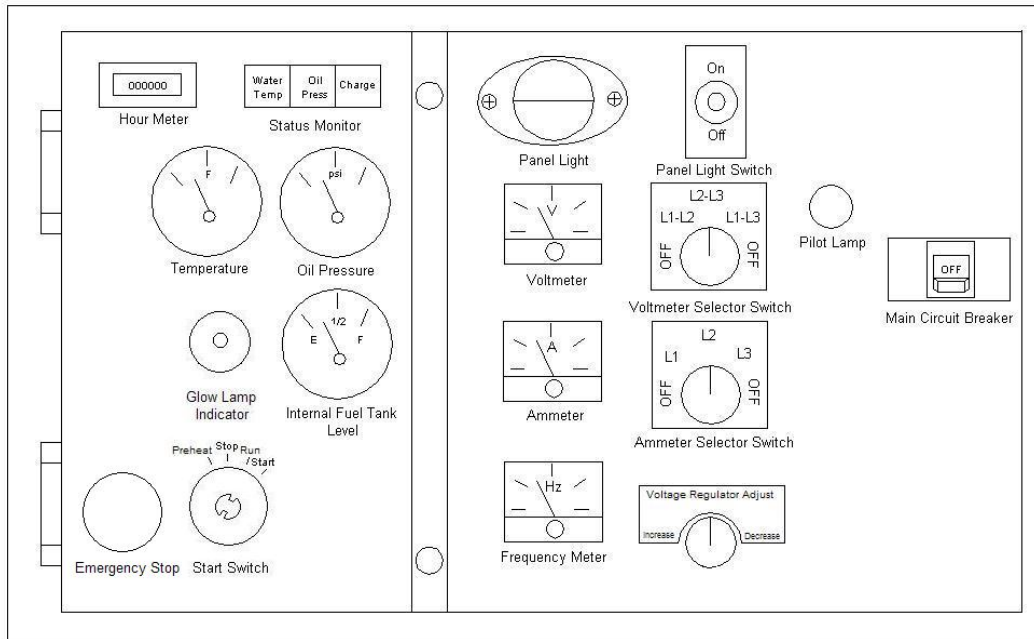

### DGK100B

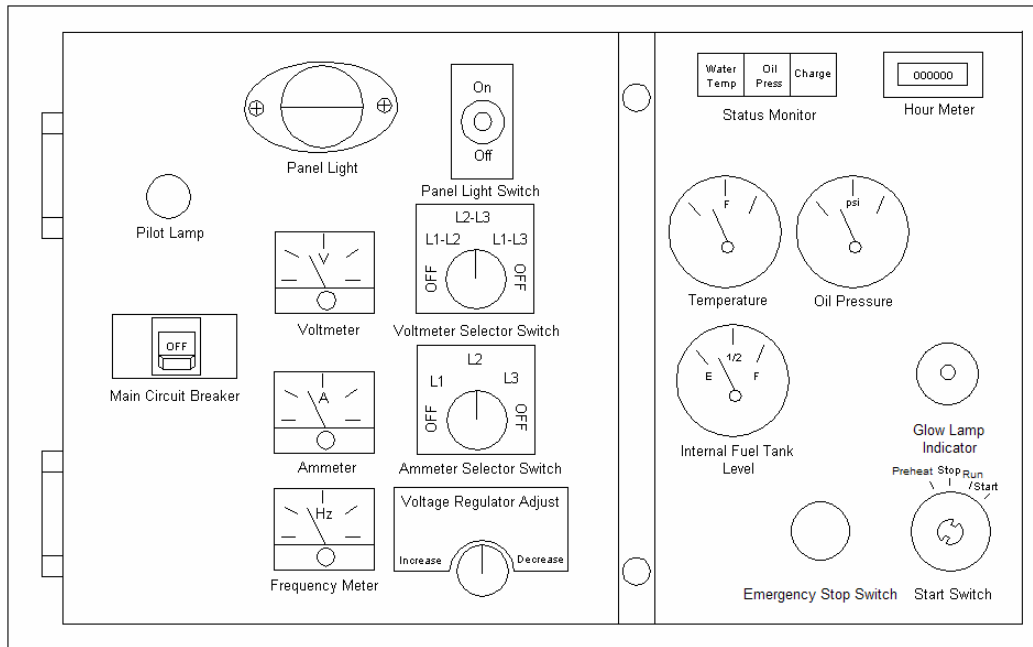

## 5.7 Main Terminal Board

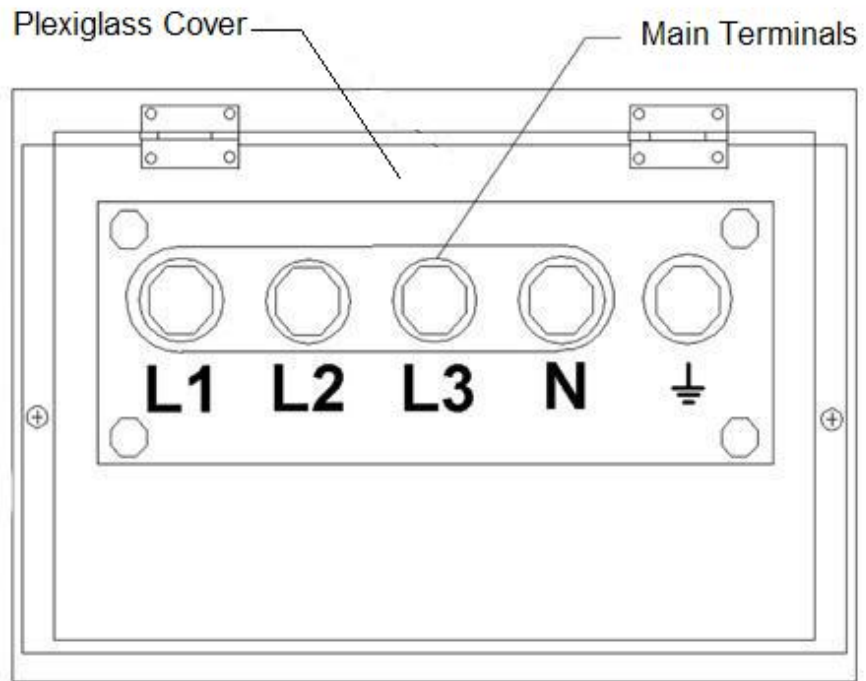

## 5.8 Receptacle Panels

**Note:** All duplex receptacles are GFCI protected and are rated at 20 amps. All Twist Loc receptacles are rated at 50 amps.

### DGK25A

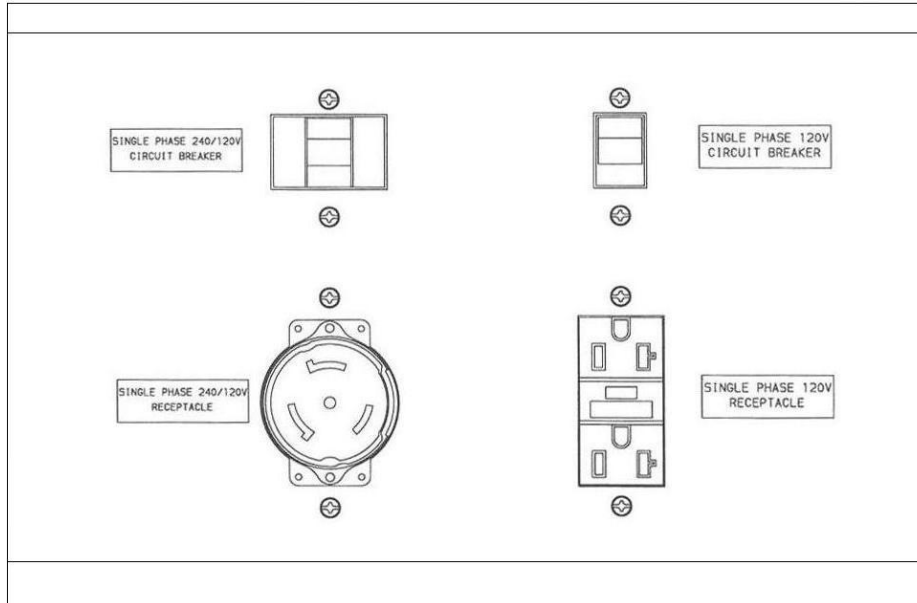

### DGK25B

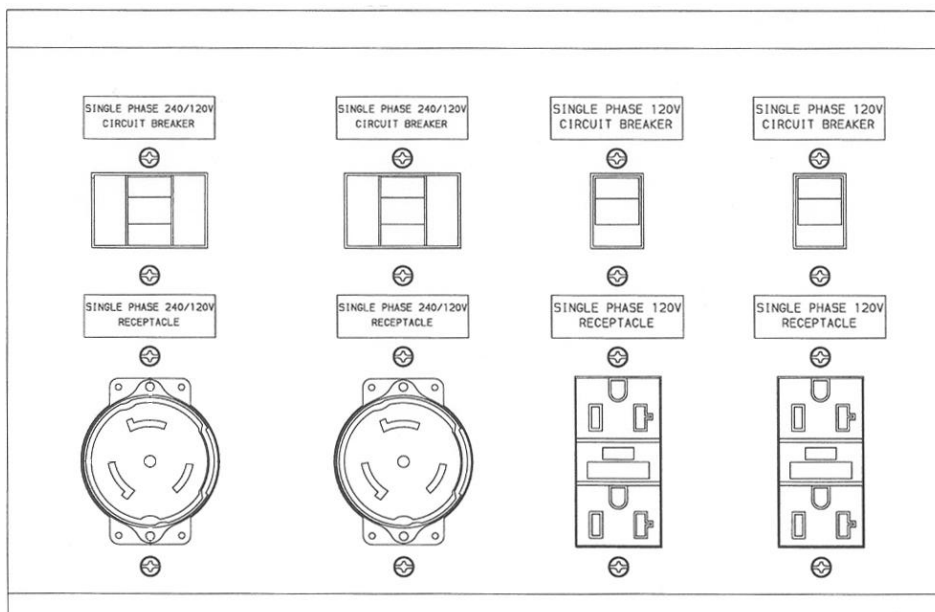

### DGK45A and DGK60A

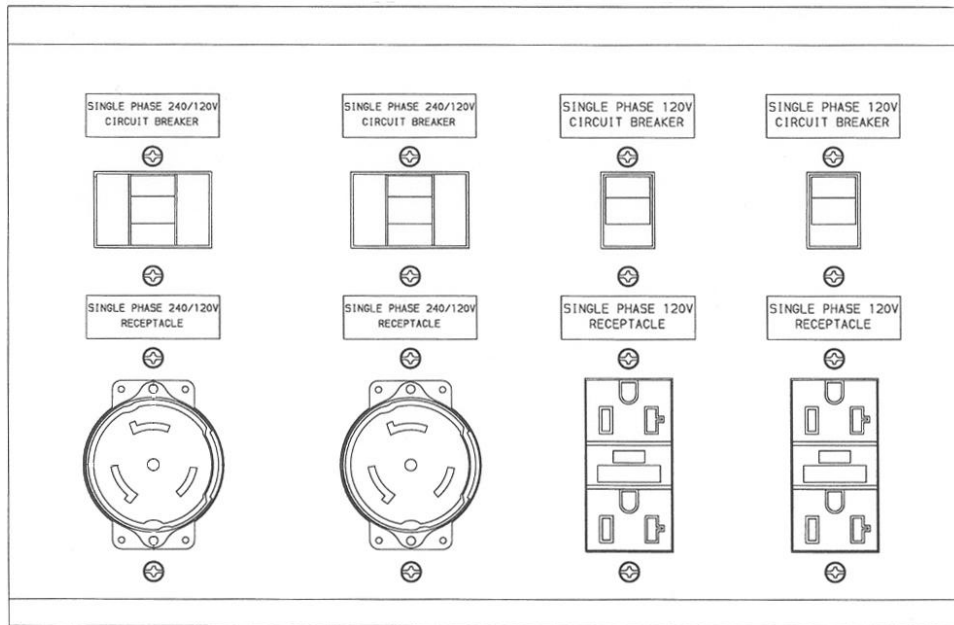

### DGK45C / DGK70B / DGK100B

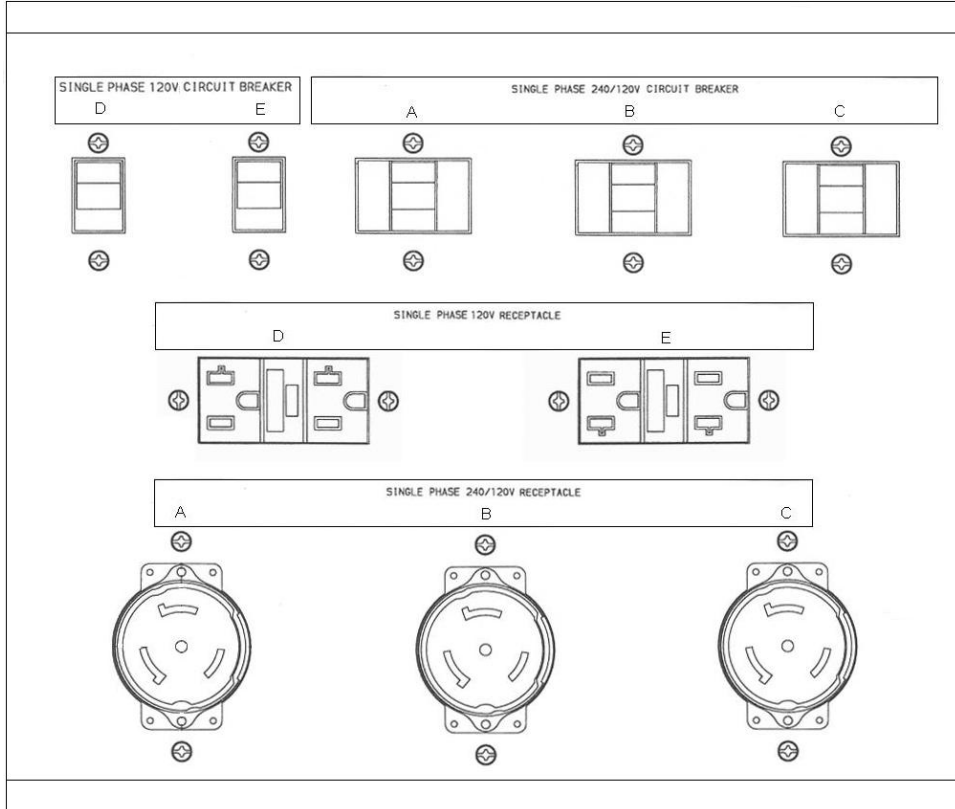

## 6. Equipment

### 6.1 Monitor Displays

These diesel generator sets are equipped with monitoring functions for coolant temperature, oil pressure, and battery charge condition.

Under normal operating conditions, these monitoring lamps will come on momentarily when the engine is first started but will go off very shortly thereafter.

If an abnormal condition is detected in coolant temperature or oil pressure, the corresponding monitor lamp will flash and the automatic shutdown will be activated. This will cause the engine to shut down. Insufficient battery charging will cause the light to flash only.

If an automatic shutdown is activated, check for and correct the cause of the shutdown prior to trying to restart the generator set.

#### Coolant Temperature Monitoring Lamp

#### **▲CAUTION**

##### **Injuries**

- To avoid injuries by unintentional contact with the cooling fan and/or fan belts, close and lock all doors while operating this equipment.

##### **Burns**

- To avoid sustaining burns from hot vapor, do not open the radiator cap while operating or immediately after stopping this equipment.
- Due to extremely high temperatures, do not come in contact with the engine and/or muffler while operating or immediately after stopping this equipment.

If the coolant temperature reaches 212° Fahrenheit increasing during operation, the coolant temperature monitoring lamp will flash, and the automatic shutdown will activate.

If this occurs, check the coolant reservoir tank, and replenish coolant if needed (refer to 9.3 *Checking Engine Coolant*).

If the coolant level is normal, check for a loose fan belt or possible water leak in the cooling system. Always allow the engine to cool down prior to making these checks.

#### **CAUTION**

- If the coolant level is too low, the temperature sensor cannot detect the coolant temperature. Always check the water level in the radiator and the coolant reservoir tank prior to operating this equipment.

## Engine Oil Monitoring Lamp

### **▲ DANGER**

#### **Injuries**

- To avoid injuries by unintentional contact with the cooling fan and/or fan belts, close and lock all doors while operating this equipment.

### **▲ CAUTION**

#### **Burns**

- Due to extremely high temperatures, do not come in contact with the engine and/or muffler while operating or immediately after stopping this equipment.
- When checking or changing engine oil, always stop the engine and wait until the engine cools down. Opening either the line to the oil gauge or the oil filler cap during operation may cause injury due to hot oil.

If the engine oil pressure drops below 10 psi during operation, the oil pressure monitoring lamp will flash, and the automatic shutdown will activate. If this occurs, check the engine oil level, and fill to the maximum level if needed.

### **CAUTION**

- The oil pressure sensor cannot detect engine oil degradation due to extended use. Oil change intervals listed under section 11 must be strictly adhered to.

## Battery Charge Monitoring Lamp

Insufficient battery charge during operation will cause the battery charge monitoring lamp to flash. If this occurs, check the condition and tightness of the fan belt and replace or tighten if necessary.

### **CAUTION**

- For changing the belt, refer to the engine Workshop Manual.
- The Battery Charge Monitor cannot detect the degradation of battery life or the battery fluid level (refer to 9.7 *Checking the Battery*).

## 6.2 Meters and Gauges

### Hour Meter

The hour meter keeps track of run time. This meter should be used to schedule preventive maintenance. **Note:** The hour meter will continue to operate as long as the start switch is in the ON position, regardless of whether the engine is actually running or not.

### Volt Meter

The volt meter displays the voltage output from the generator. The voltage displayed will be dependent on the position of the voltage selector switch. For single-phase operation it will display **L1** or **L3** voltage only.

### Ammeter

The amp meter displays the electrical current output from the generator. The amperage displayed will be dependent on the position of the amp meter selector switch. For single-phase operation it will display **L1** or **L3** phase amperage only.

### Frequency Meter

The frequency meter will display the frequency of the generated power.

### Coolant Temperature Gauge

This gauge indicates the temperature of the engine coolant in degrees Fahrenheit. Under normal operating conditions this gauge should read approximately 180 °F to 200 °F.

### Oil Pressure Gauge

This gauge indicates the oil pressure of the engine in pounds per square inch. Under normal operating conditions this gauge should read approximately 40 to 60 pounds per square inch.

### Fuel Gauge

This gauge indicates the fuel level in the internal fuel tank only. If there is an external fuel tank being used to supply fuel to the generator this gauge will not indicate the fuel level of that tank.

## 6.3 Lamps and Lights

### Glow Lamp

When the start switch is turned to the Run/Preheat position, the Glow Lamp will light to indicate that the glow plugs are energized and preheating the engine cylinders. When the preheating is completed, the lamp will go off, indicating that the engine is ready to be started.

### CAUTION

- Preheating time may vary from 1 to 5 seconds, depending on the coolant temperature.

### Pilot Lamp

The pilot lamp is located on the generator control panel and indicates whether or not the engine is running. When the lamp is lit the engine is running. When the lamp is not lit the engine is not running.

### Panel Light

The panel light is located on the generator control panel and is used to illuminate the generator and engine control panels. This light is turned on and off with the panel light toggle switch which is also located on the generator control panel next to the panel light. This light can only be energized when the engine is running.

## 6.4 Switches

### Start Switch

The Start Switch is a three position switch that is used for starting, stopping, and preheating the engine.

#### POSITIONS:

#### STOP:

When the switch is set to this position, all power will be off. The switch must be set to this position to remove the key.

#### OPERATING/PREHEATING:

The switch must be set to this position during operation. This position is also used to preheat the glow plug and for removing air from the fuel lines.

## **CAUTION**

- Do not leave the switch in this position, while the engine is stopped. It may drain the battery.

### **START:**

This position allows the user to start the engine. When the operator releases the key while in this position, the switch will automatically return to the Operating/Preheating position.

### **Voltmeter Selector Switch**

The voltmeter selector switch is a 5 position switch located on the generator control panel next to the voltmeter that selects which phase voltage the voltmeter will be displaying. There are two off positions for this switch, one at the far left position and one at the far right position. In the off positions the voltmeter will not be displaying any voltage. In the L1-L2 position the voltmeter will display the phase voltage between phase L1 and phase L2. In the L2-L3 position the voltmeter will display the phase voltage between phase L2 and phase L3. In the L3-L1 position the voltmeter will display the phase voltage between phase L3 and phase L1. This switch must be in the L1-L3 position to read single phase voltage.

### **Ammeter Selector Switch**

The ammeter selector switch is a 5 position switch located on the generator control panel next to the ammeter that selects which phase current the ammeter will be displaying. There are two off positions for this switch, one at the far left position and one at the far right position. In the off positions the ammeter will not be displaying any amperage. In the L1 position the ammeter will display phase L1 current. In the L2 position the ammeter will display phase L2 current. In the L3 position the ammeter will display phase L3 current. This switch must be in the L1 or L3 position to read single phase current.

### **Voltage Selector Switch**

The voltage selector switch is a lockable 3 position switch located directly above the terminal connection panel. This switch provides a quick, convenient method of changing the generator output voltage. This switch should never be operated while the generator is running. The Three Phase 480/277 position gives an output from the generator of 480 volts three phase or 277 volts single phase. The Three Phase 240/139 position gives an output from the generator of 240 volts three phase or 139 volts single phase. The Single Phase 240/120 volt position gives a single phase output from the generator of 240 volts or 120 volts.

### **Panel Light Toggle Switch**

This switch is located on the generator control panel next to the Panel Light. It is used to turn the panel light on and off. To prevent leaving this light on and draining the battery, this switch can only turn the Panel Light on when the generator is running.

### **Emergency Stop Switch**

This switch is installed on the DGK45C, DGK70B, and DGK100B and is located just to the left of the start/stop switch on the engine control panel. It is a red momentary contact type switch that will immediately stop the engine when it is pushed.

## 6.5 Output Circuit Breaker

The Output Circuit Breaker is located on the control panel and is used for connecting and disconnecting the load from the output of the generator. Turning the circuit breaker to the ON position will allow power to be supplied to the load. Turning the circuit breaker to the OFF position will remove all power from the load. The breaker will also trip and remove power from the load in the event that there is an overload condition on the generator.

## 6.6 Voltage Adjustment Knob

The Voltage Adjustment Knob is used to adjust the generated output voltage of the generator. Turning the voltage adjust knob clockwise will increase the generated voltage. Turning the voltage adjust knob counter-clockwise will decrease the generated voltage. The adjustment range available with this knob is plus 6.5% and minus 15%.

## 6.7 Three Way Fuel Valves

### **⚠ CAUTION**

#### **Burns**

- Always stop the engine prior to performing any work on fuel lines.
- Immediately wipe up any fuel leakage.

The 3-Way valves provide a quick and convenient method of using an external fuel tank as a fuel supply for the engine. If an external fuel supply is being used, the internal fuel tank is not available as a supply of fuel for the engine.

### **6.7.1 Using Fuel From The Internal Tank**

The 3-way valve is set to the **A** position when the equipment is shipped. This position allows the fuel from the internal tank to be used as a fuel source for the engine. In addition, both the external fuel intake and the external fuel return lines are plugged with 3/8 inch pipe plugs. Always ensure that the external fuel intake and return are plugged with the supplied plugs or is connected to an external fuel tank while using the internal fuel tank as the fuel source.

### **CAUTION**

Always set the 3-way valve back to the **A** position and cover the external fuel intake and fuel return ports with the supplied plugs, whenever the internal fuel tank is being used as the fuel source.

### 3- Way Valve Fuel Return Line in the A Position (Using Internal Fuel Tank)

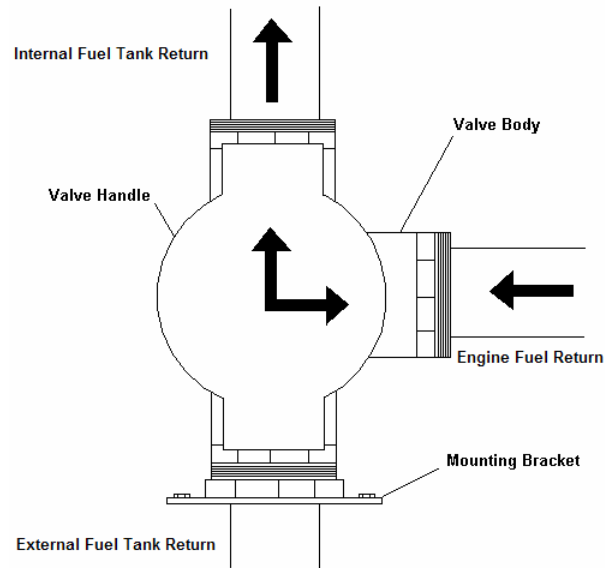

### 3- Way Valve Fuel Suction Line in the A Position (Using Internal Fuel Tank)

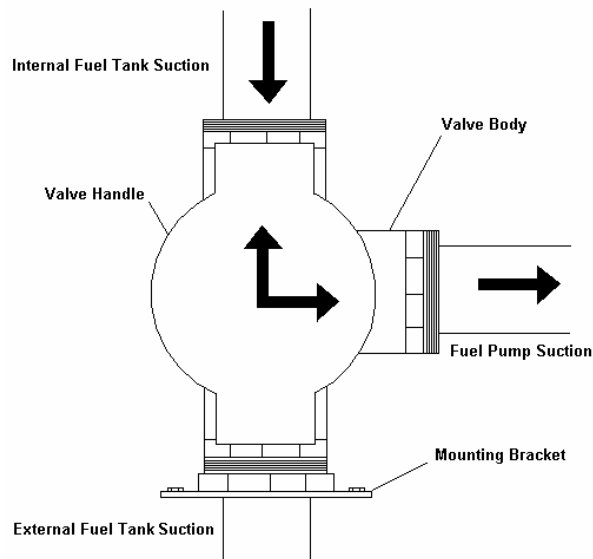

### 6.7.2 Using Fuel From The External Fuel Tank

Connect hoses from the external fuel tank to the external fuel intake and the external fuel return ports, and set the 3-way valve to the **B** position. You can now supply fuel from the external fuel tank. For detailed instructions, (refer to Section 10.6 *Connecting to an External Fuel Tank*).

#### 3- Way Valve Fuel Return Line in the B Position (Using External Fuel Tank)

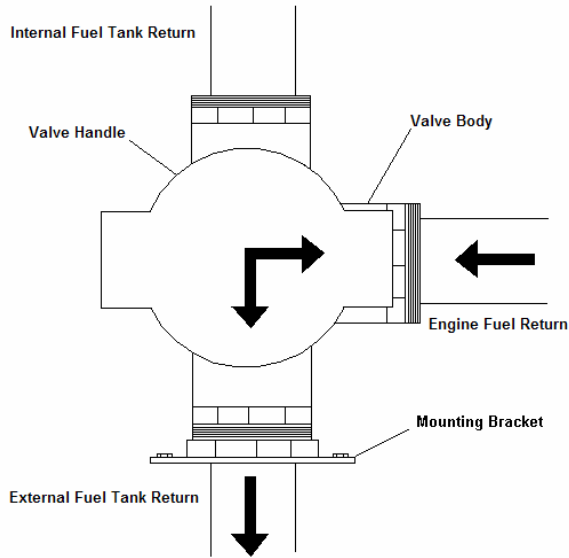

#### 3- Way Valve Fuel Suction Line in the B Position (Using External Fuel Tank)

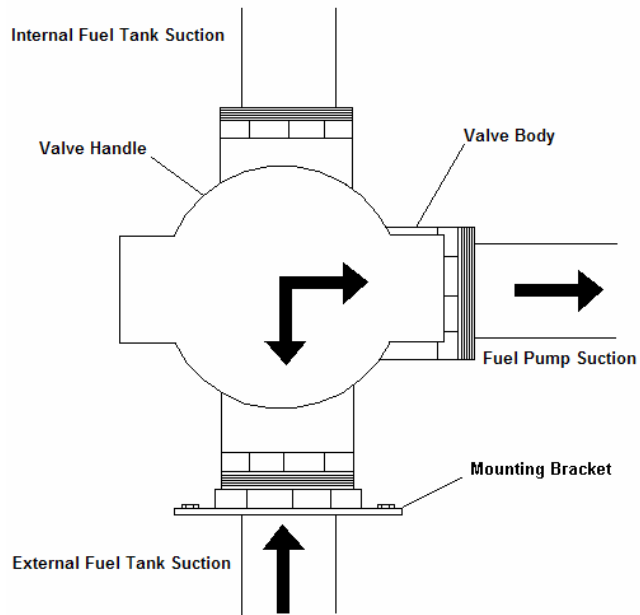

### **6.7.3 Three Way Valves Locations**

The Three Way Valves are located on the right side of the generator enclosure (when viewed from the control panel end), very near the enclosure upright. They are enclosed within the generator bed frame. On the DGK45C they are located on the left side of the generator enclosure. They are a distinctive orange color with black directional arrow markings.

## 7. Lifting, Transporting, and Installing

### **⚠ DANGER**

- The lifting hook is designed to lift only the generator. Do not lift any additional added weight such as fuel tanks and/or trailers with the lifting hook.

### **⚠ CAUTION**

#### **Injuries**

- Use only the installed lifting hook for lifting this equipment.
- Do not use the tie down posts for lifting. They are not designed to hold the weight of this equipment.

### 7.1 Lifting

Always use the installed lifting hook, whenever lifting this equipment. **This lifting hook is designed to lift only the generator. Do not lift any additional added weight such as fuel tanks and/or trailers with this lifting hook. Do not lift with the tie downs.**

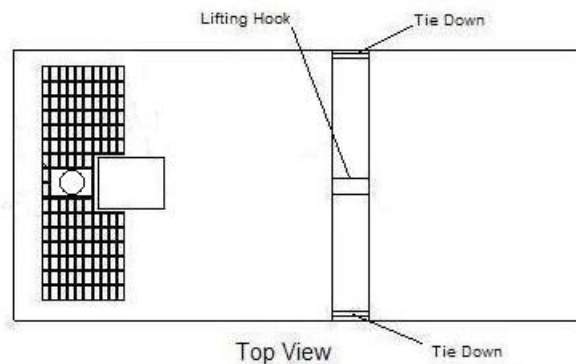

### 7.2 Transporting

When transporting this equipment, make sure that the equipment is properly secured using the tie down posts.

### **CAUTION**

- Always use extreme care when loading, unloading, and transporting this equipment. Failure to do so may result in damages to and/or malfunction of the equipment.

## 7.3 Installing

### **⚠ DANGER**

#### **Suffocation from exhaust fumes**

- Exhaust fumes from the engine on this equipment contain many elements that have been proven to be harmful to humans. Do not operate this equipment in poorly ventilated areas such as inside a room or in a tunnel.
- Do not direct exhaust fumes toward pedestrians or buildings.

### **⚠ CAUTION**

#### **Fire**

- This equipment must be operated only on flat surfaces and at least 3 feet away from any obstructions (such as walls) that could hinder airflow.
- Temperatures around the muffler and exhaust piping can get extremely high. Keep any flammable items (such as fuel, gas, paint, etc.) away from these areas.

### **CAUTION**

- This equipment must be operated on a hard and flat surface. Operating under any other conditions may result in damage to or malfunctions of the equipment.
- Do not block the airflow from the radiator output or muffler exhaust. This may result in reduced engine performance, overheating, or other significant damage.
- Operating in abnormally dusty, salty or high particulate environments may result in fouling of the radiator or air cleaner. The frequency of maintenance and operating checks should be increased when operating this equipment in these types of environments.

## 8. Connecting Cables

### **⚠ DANGER**

#### **Electrical Shock**

- Before connecting or disconnecting load cables from the output terminals, always turn the output circuit breaker to the OFF position, stop the engine, and remove the engine key. The person performing the connection or disconnection should always keep the key.

### **Cable connection Terminal Board (3-phase/single phase) 480 Volt Three Phase and 277 Volt Single Phase Switch Position**

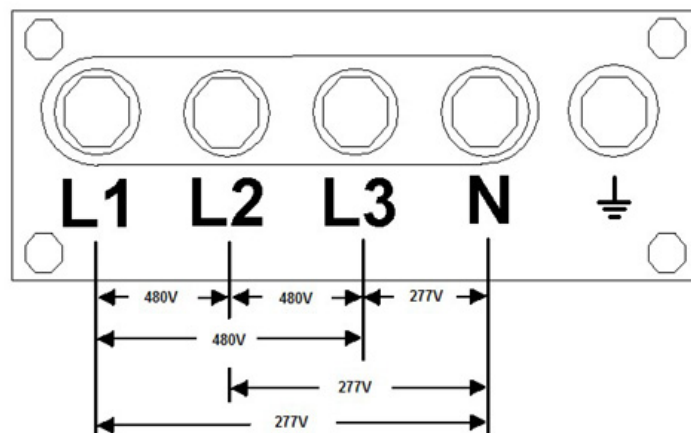
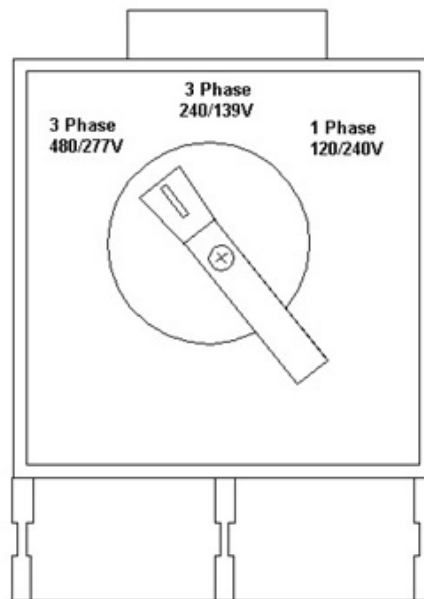

**240 Volt Three Phase and 139 Volt Single Phase Switch Position**

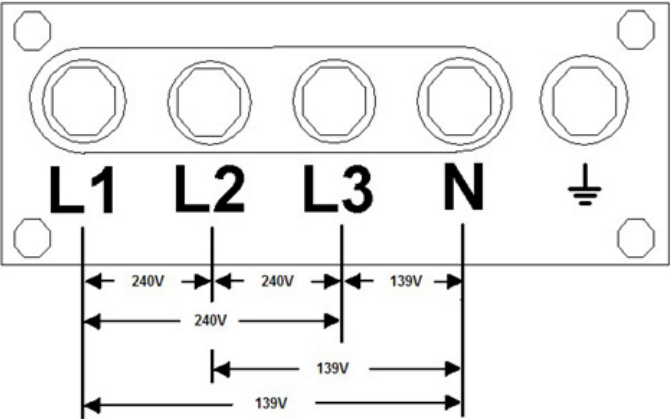
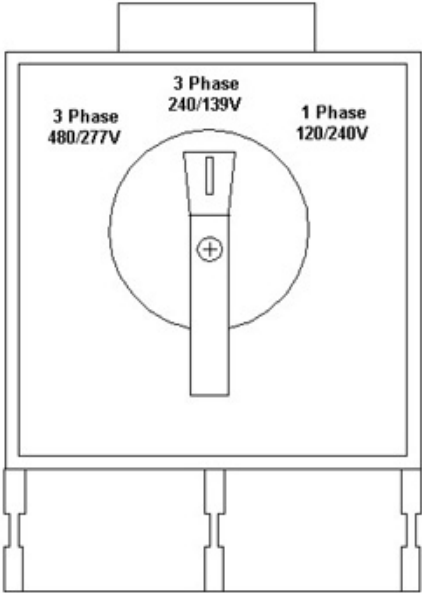

### 208 Volt Three Phase and 120 Volt Single Phase Switch Position

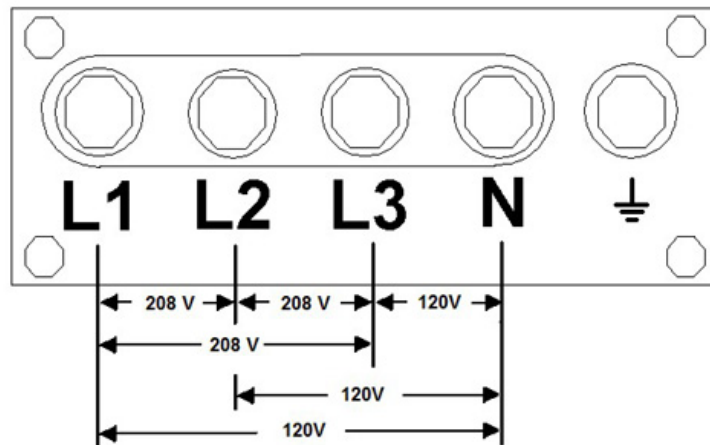
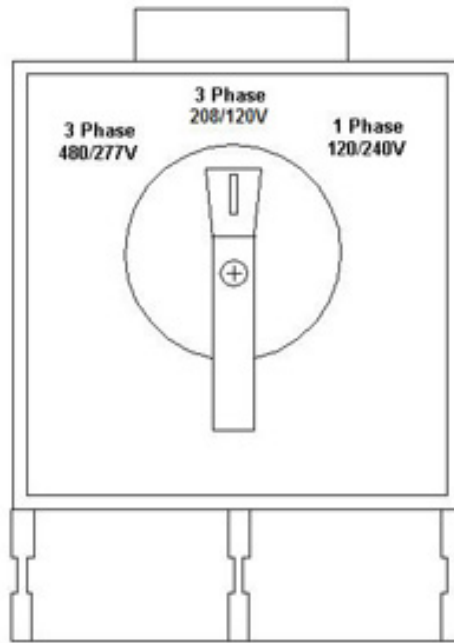

### 240 Volt Single Phase and 120 Volt Single Phase Switch Position

**Note:** Place the voltmeter selector switch in the L3-L1 position and the ammeter selector switch in the L1 or L3 position when the Voltage Selector Switch is in the 1 Phase 240/120V position.

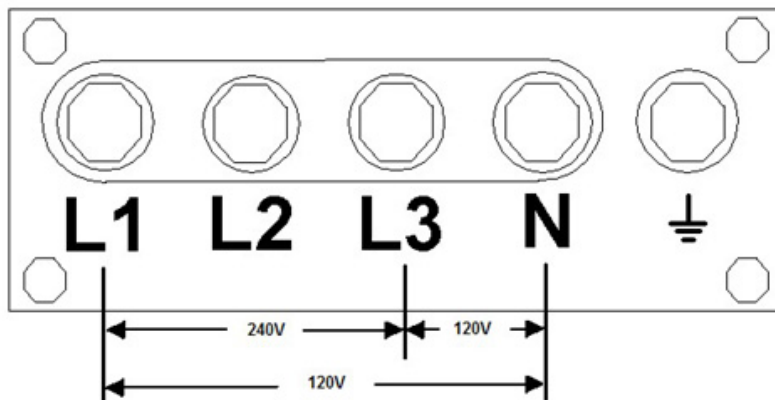
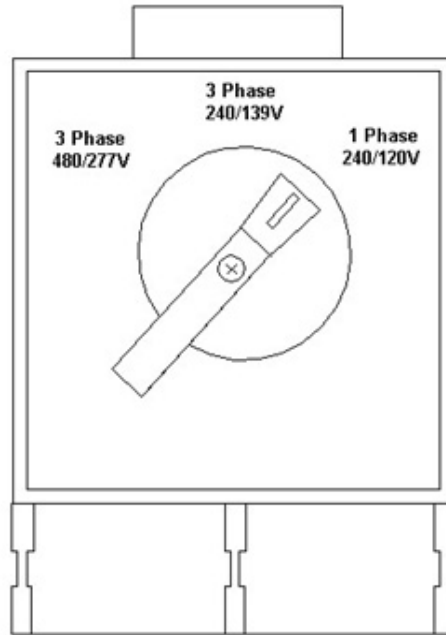

## 9. Initial Startup and Pre-Checks

### **⚠ DANGER**

#### **Electrical Shock**

- Prior to performing any equipment check or maintenance, stop the engine and remove the engine key. The person performing the equipment check or maintenance should always keep the key.

### **⚠ CAUTION**

#### **Burns**

- Prior to performing any engine checks or adjustments, stop the engine. Wait until the engine cools down, before performing any checks or adjustments.

#### **Fire**

- Always immediately wipe up any spilled or dripped fuel or oil. If a leak is found, do not use this equipment until the cause of the leak has been determined and remedied. Complete repairs to the equipment before further use.

### 9.1 Checking Engine Oil

*(Also, please refer to the accompanying Instruction Manual for the engine)*

When checking the engine oil, be sure to keep the equipment level and insert the dipstick fully.

Prior to starting the engine, make sure to fill the engine oil to the MAX line through the oil filler tube.

### **⚠ CAUTION**

- If the equipment is not level, you cannot obtain an accurate oil level reading.
- Do not overfill the engine with oil. Too much engine oil could damage the engine.

1. Remove the dipstick from the crankcase and wipe it clean with a clean cloth.
2. Reinsert it fully and then gently remove it again.
3. Check the oil level on the dipstick. The level must be between the "Max" level mark and the "Min" level mark.
4. If the level is above the "Max" mark, drain oil until the level is at or below the "Max" level mark.
5. If the level is at or below the "Min" level mark, add oil until the level is above the "Min" level mark.

## 9.2 Selecting the Proper Engine Oil

Use engine oil specifically designed for diesel engine use with the proper viscosity based on the anticipated ambient temperature (refer to the chart below).

**Oil Viscosity and Temperature**

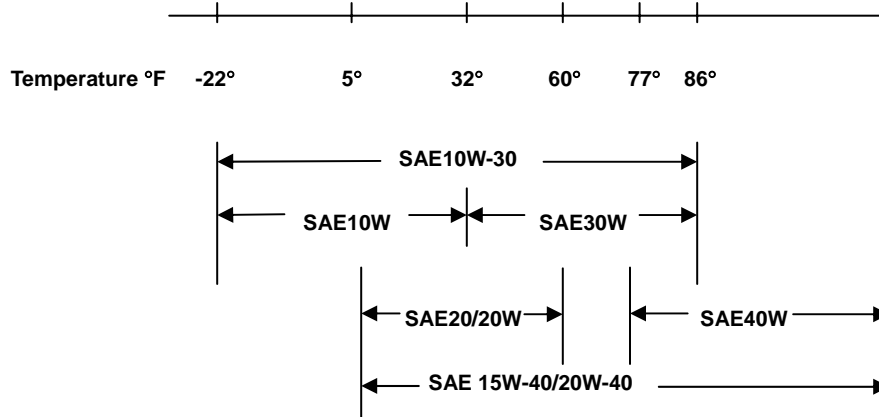

### CAUTION

- Use API class CC grade or higher engine oil.

## 9.3 Checking Engine Coolant

*(Also, please refer to the accompanying Instruction Manual for the engine)*

### ⚠ DANGER

#### Injuries

- Prior to performing any equipment check or maintenance, stop the engine, and remove the engine key. The person performing the equipment check or maintenance should always keep the key.

### ⚠ CAUTION

#### Burns

- To avoid sustaining burns from hot vapor, do not open the radiator cap while operating or immediately after stopping this equipment.
- Due to extremely high temperatures, do not touch the engine or muffler while operating or immediately after operation of this equipment.

### 9.3.1 Checking Radiator Level/ Adding Coolant

*(Also, please refer to the accompanying Instruction Manual for the engine)*

1. Remove the radiator cap which is located under the removable plate bolted on the top of the generator top cover. The coolant level should be up to the filler port neck. If not, add coolant. The coolant should be a 50/50 mix of GM SPEC 6277M or equivalent long life Coolant/Water.
2. Fill the radiator with coolant until it reaches the filler port neck. Fill slowly to prevent air entry.
3. Reinstall the radiator cap and tighten.
4. Recheck the level after a few minutes of running the engine and refill if necessary.

### 9.3.2 Checking the Coolant Reservoir Tank Level/ Adding Coolant

*(Also, please refer to the accompanying Instruction Manual for the engine)*

1. Ensure the coolant level is between the MIN and the MAX line.
2. If the coolant level is low, add the same mixture of coolant used in the radiator to fill the reservoir tank to the MAX line.

#### **CAUTION**

- Always use potable water when mixing coolant.
- Do not spill antifreeze or engine coolant on the exhaust system or hot engine parts. Under some conditions the long life coolant is combustible.

### 9.4 Checking the Fan Belt

*(Also, please refer to the accompanying Instruction Manual for the engine)*

#### **⚠ DANGER**

##### **Injuries**

- Before performing any equipment check or maintenance, stop the engine, and remove the engine key. The person performing the equipment check or maintenance should always keep the key.
- To avoid injuries by unintentional contact with the cooling fan or fan belt, close and lock all doors while operating this equipment.

#### **⚠ CAUTION**

##### **Burns**

Due to extremely high temperatures, do not touch the engine or muffler while operating or immediately after stopping the equipment.

### 9.4.1 Tension

The fan belt should have  $\frac{1}{4}$  to  $\frac{1}{2}$  inch slack when applying finger pressure at the midpoint between the fan pulley and the alternator pulley.

### 9.4.2 Condition

Check the fan belt for any damage and replace if necessary.

#### CAUTION

- Refer to the Instruction Manual for the engine to adjust or replace the fan belt.

### 9.5 Checking the Fuel Level

#### ▲CAUTION

##### Fire

- Always immediately wipe up any diesel fuel or engine oil that is spilled. Do not use this equipment if there are any leaks. Repair the equipment before further use.

Prior to starting the engine check the level of the fuel in the tank that is currently supplying fuel. The fuel gauge on the control panel shows only the level of the fuel in the internal tank (three way valves in the A position). If an external fuel tank is connected and being used as the fuel source three way valves in the B position), the fuel level in this tank is monitored and read separately from the gauge on the control panel.

#### CAUTION

- Ensure the fuel strainer is installed in the neck of the fill spout.
- Fill the tank to slightly less than the FULL mark.

### 9.6 Checking for Leaks

#### ▲CAUTION

##### Fire

- Do not use this equipment if there are any leaks. Repair the equipment before further use.
- Check all hose connections for leakage.

Prior to starting the engine make a complete and thorough inspection of the engine to ensure there are no fuel leaks.

## 9.7 Checking the Battery

### **▲CAUTION**

#### **Injuries to eyes and skin**

- Battery fluid contains diluted sulfuric acid. Avoid contact with eyes, skin or clothing. If contact with the acid does occur, especially with the eyes, immediately flush with large volumes of water, and contact a physician.

#### **Fire**

- The battery may emit highly explosive gases. Never expose it or the surrounding area to flames or spark producing devices.

The battery (or batteries) shipped with this generator is a hermetically sealed dry charged battery requiring the addition of dilute sulfuric acid prior to its initial use. It is activated instantaneously, without any initial charge, just by filling it with electrolyte. It is sealed with aluminum foil or sealing tape that should never be removed until just before adding the dilute sulfuric acid.

#### **Preparation for Service:**

1. Place the battery on a flat surface and take off the aluminum foil or sealing tape on the vent-holes of the individual cells.
2. Slowly and carefully fill each cell to the upper level with dilute sulfuric acid (specific gravity of 1270 to 1280) prepared specifically for use as battery electrolyte.
3. Let the battery stand for a few minutes. Check that each cell is still at the upper level and refill as necessary.
4. Install the cell vent plugs.

Make sure the battery cables are firmly tightened to the posts. Tighten the battery cable clamps if necessary.

#### **Operating:**

1. Unless the battery is filled with electrolyte immediately after removing the aluminum foil or sealing tape, it loses its dry-charge characteristics.
2. In cold weather, a fast charge for a short period of time is recommended before placing the battery in service.
3. Use distilled water to refill cells that are below the upper level. Never use sulfuric acid.
4. Do not leave the battery out of service for longer than one month once it is filled with electrolyte. If it has been out of service for a month or longer do a refreshing charge prior to use.

#### **If battery replacement is necessary, use the following procedure for replacing the battery:**

1. Remove the clamp and cable from the negative (-) post. Always remove the negative clamp and cable first.
2. Remove the hold-down clamp.
3. Remove the clamp and cable from the positive (+) post.
4. Remove the battery from the battery rack.

\* Reinstall the new battery in the reverse order.

## 10. Operation

### ▲ DANGER

#### Suffocation from exhaust fumes

- Exhaust fumes from the engine on this diesel generating set contain many elements that have been proven to be harmful to humans. Do not operate this equipment in poorly ventilated areas such as inside a room or in a tunnel.
- Do not direct exhaust fumes toward pedestrians or buildings.

### ▲ CAUTION

#### Fire

- Temperatures around the muffler and exhaust piping can get extremely high. Keep any flammable items (such as fuel, gas, paint, etc.) away from these areas.
- This equipment must be operated only on flat surfaces and at least 3 feet away from any obstructions (such as walls) that could hinder airflow.

#### Injuries

- Always place the equipment on a flat and stable surface to keep it from sliding.
- Before starting the engine, turn off the connected equipment and turn the generator output circuit breaker to the OFF position.

### 10.1 Starting

1. Turn the output circuit breaker on the control panel to the **OFF** position.
2. Turn the starter switch to the **Start** position.
3. As soon as the engine starts, release the starter switch.
4. In cold temperatures, turn the starter switch to the **Operating/Preheat** position until the preheat lamp turns on and then turn it to the **Start** position.

### CAUTION

- Preheating time may vary from 1 to 5 seconds.
- Do not crank the starter motor for more than 10 seconds at a time.
- If the engine does not start, wait at least 30 seconds before retrying.

5. After the engine starts, ensure all the monitor lamps remain **off**.
6. Run the engine at idling speed without load for at least 10 minutes.

### 10.2 Loading the Generator

1. Set the required voltage using the voltage adjusting knob.
2. Turn the generator output circuit breaker to the **ON** position to apply power to the load terminals.

### ▲ DANGER

#### Electrical Shock

- Before connecting or disconnecting load cables from the output terminals, always turn the output circuit breaker to the OFF position, stop the engine, and remove the engine key. The person performing the cable connection or disconnection should always keep the key.

### 10.3 Operating the Generator

1. In the event the generator output breaker trips **OFF**, make the necessary correction or repair (or decrease the load) prior to resetting the breaker by first turning it to the **OFF** position, and then back to the **ON** position.
2. When any **RED** warning monitor lamp turns **ON**, stop operation immediately and correct the fault before resuming operation.

### 10.4 Stopping the Generator

1. Turn the load breaker(s) to the **OFF** position.
2. Turn the generator output circuit breaker to the **OFF** position and allow the engine to run at idling speed for about 3 minutes for cooling down.
3. Turn the starter switch to the **STOP** position.

### 10.5 Automatic Shutdowns

This generator is equipped with automatic shutdowns. This feature activates automatically with display in the event of an alarm situation. If an automatic stop device has activated, turn the starter switch to the STOP position. Correct the cause(s) of the automatic shutdown prior to trying to restart the generator.

Automatic Shutdown List

No.	Symptoms	Action			Cause
		Circuit Breaker OFF	Automatic Engine Shutoff	Alarm Lamp Flash	
<b>Monitor Lamp</b>					
1	High Coolant Temperature	--	X	X	Engine coolant temperature is too high (activates at 212 ° F increasing)
2	Low Oil Pressure	--	X	X	Engine oil pressure too low (activates at 10 psi decreasing)
3	Insufficient Charge	--	--	X	When the battery can no longer hold a charge

## 10.6 Connecting to an External Fuel Tank

### ⚠CAUTION

- Stop the engine prior to commencing external fuel tank connections.
- Always immediately wipe up any diesel fuel or engine oil that is spilled. Do not use this equipment if there are any leaks. Repair the equipment before further use.

1. Turn the 3-way valve to the **A** position.
2. Disconnect the 3/8 inch pipe plugs from both the external fuel intake and the external fuel return lines and connect the hoses from the external fuel tank, ensuring that the suction and return are connected to the proper plugs.
3. Turn the 3-way valve to the **B** position.
4. Vacuum out the air from connected hoses. This will allow the use of the fuel from the external fuel tank.

### CAUTION

- To vacuum out the air from the external fuel lines turn the starter switch to the **Operating/Preheating** position and hold it there for approximately 10 seconds.
- To avoid leaks from the external fuel intake or the external fuel return ports, always turn the 3-way valve to the **A** position while connecting or disconnecting the external fuel tank lines.
- Use extreme caution when connecting the external fuel tank lines. If the 3-way valve is not set properly, fuel may leak from either the internal fuel tank or the external fuel tank.

## 11. Maintenance

### **⚠ DANGER**

#### **Electrical Shock**

- Before performing any equipment check or maintenance, stop the engine, and remove the engine key. The person performing the equipment check or maintenance should always keep the key.

### **⚠ CAUTION**

#### **Burns**

- To avoid sustaining burns from hot vapor, do not open the radiator cap while operating or immediately after stopping this equipment.
- Due to extremely high temperatures, do not touch the engine or muffler while operating or immediately after stopping this equipment.
- When checking or changing engine oil, always stop the engine, and wait until the engine cools down. Opening either the line to the oil gauge or the oil filler cap during operation may cause injury due to hot oil.

#### **Fire**

- Always immediately wipe up any diesel fuel or engine oil that is spilled. Do not use this equipment if there are any leaks. Repair the equipment before further use.

To maximize the useful life of this generator, follow the recommended periodic equipment and maintenance checks according to the following table. The hour meter should be used as a guide for actual operating time.

### **CAUTION**

- With the exception of the pre-startup and operating checks, only qualified technicians should perform the equipment and maintenance checks.
- Maintenance items marked with **XX** should be referred to the nearest authorized dealer.
- This chart covers only basic checks and maintenance for the engine. For more detailed maintenance information for the engine refer to the Instruction Manual for the engine.
- For maximum performance and useful life, always use genuine replacement parts.

Description	Startup Check	Every 200 hrs	Every 400 hrs	Every 500 hrs	Every 1000 hrs	Every 2000 hrs
<b>Engine</b>						
Engine oil check / add oil	X					
Engine oil change ( <i>1<sup>st</sup> time at 50 hr mark</i> )	X	X				
Oil Filter change	X		X			
Coolant level check / add coolant	X					
Exhaust color check	X					
Coolant change						X
Clean or replace fuel filter		X		X		
Drain water from fuel tank		X				
Clean inside fuel tank					XX	
Leak check (fuel, oil, and coolant)	X					
Replace fuel hose					XX or 1 yr.	
Clean or replace air cleaner element		X Clean		X Replace		
Battery fluid level check	X					
Battery hydrometer check				X		
Fan belt check	X					
Flush Radiator				XX		
Check and adjust engine valve clearance					XX	
Compression check					XX	
Fuel injection nozzle check			XX			
Fuel injection timing check					XX	
<b>Generator</b>						
Meters, gauges and alarm lamps	X					
Insulation test		X				

## 11.1 Oil Change

### Frequency

First time	50 hours
Thereafter	Every 200 hours

### Procedure

1. Remove the oil fill cap.
2. Loosen the engine oil drain plug and allow the oil to drain completely.
3. Reinstall the drain plug.
4. Add oil to the Max line on the dipstick (approximately 2quarts). Do not overfill.
5. Reinstall the filler cap hand-tight.

## CAUTION

Use only engine oil designated API CC grade or higher.

## 11.2 Oil Filter Change

### Frequency

First time	50 hour mark
Thereafter	Every 400 hours

### Procedure

1. Drain the engine oil completely, as described in section 11.1.
2. Using an oil filter wrench, loosen and remove the oil filter.
3. Lightly coat the rubber gasket of the new oil filter with some of the new engine oil.
4. Screw the new filter into place and hand tighten it until the gasket just contacts the filter seat. Then, using an oil filter wrench, give it additional 3/4 turn to seat the filter.
5. Add oil and reinstall the filler cap.

## 11.3 Cleaning/Changing the Air Filter Element

### Frequency

Clean	Every 200 hours
Replace	Every 500 hours

### Procedure

1. Unscrew the wing nut and remove the filter element.
2. Clean or replace the filter element, and reinstall it.

## CAUTION

- In dusty or other high particulate environments, increase the frequency of cleaning.
- To clean the filter element:
  - If the element has dried contaminants, it may be cleaned by blowing compressed air through it from the **inside**.
  - If the element has any carbon or grease buildup, it should be replaced with a new element.

## 11.4 Cleaning/Changing the Fuel Filter

### Frequency

Clean	Every 100 hours
Replace	Every 400 hours

### Procedure

1. Turn the butterfly fuel valve on the top of the fuel filter to the CLOSED position.
2. Unscrew the ring nut by turning it counterclockwise, and then remove the retaining cup and fuel filter element.
3. Remove any dust or water inside the cup, and then clean the filter element using compressed air (or replace, if necessary).  
\* If you are replacing the filter element, be sure to replace the O-ring as well.
4. Reassemble.

### CAUTION

- Be sure to check for any contaminants on the O-ring when reinstalling the retainer cup.
- Turn the butterfly fuel valve on the top of the fuel filter to the OPEN position after reassembling and check for any leaks.

## 11.5 Draining Water From the Internal Fuel Tank

### Frequency

Drain water	Every 200 hours
-------------	-----------------

### Procedure

1. Unscrew the fuel drain plug.
2. After completely draining any water, reinstall the drain plug.

## 11.6 Changing Engine Coolant

### ▲CAUTION

Replace only with GM SPEC 6277M or equivalent long life coolant

### Frequency

Replace	Every 2 years or 400 hours
---------	----------------------------

### Procedure

1. Remove the radiator cap.
2. Loosen the engine coolant/water drain plug.
3. Drain the engine coolant completely.
4. Reinstall the drain plug.
5. Remove the reservoir tank and empty the engine coolant that is in the tank.
6. Reinstall the reservoir tank.

7. Fill the radiator with engine coolant (a 50/50 mix of GM SPEC 6277M or equivalent long life coolant and water) to the top of the filler neck (approximately 1.9 gal). Fill slowly to prevent air entry.
8. Fill the reservoir tank with engine coolant to the Max line.
9. Reinstall the radiator cap.
10. Recheck the level after a few minutes of running the engine and refill if necessary.

## 12. Long Term Storage Procedures

### **⚠ DANGER**

#### **Electrical Shock**

- Before performing any equipment check or maintenance, stop the engine, and remove the engine key. The person performing the check or maintenance should always keep the key.

### **⚠ CAUTION**

#### **Fire**

- Temperatures around the muffler and exhaust piping can get extremely high. Keep any flammable items (such as fuel, gas, paint, etc.) away from these areas.
- Always immediately wipe up any diesel fuel or engine oil that is spilled. Do not use this equipment if there are any leaks. Repair the equipment before further use.

If the generator will not be used for more than two months, perform the following maintenance and storage procedures.

1. Remove the battery.
2. Change the engine oil.
3. Drain the fuel from the fuel tank and fuel filter.
4. Clean all parts, cover the generator, and store it away from dust and humidity.

### **CAUTION**

- Recharge the removed battery at least once a month.
- Refer to the engine instruction manual for detailed care procedures for the engine.

## 13. Troubleshooting

### **⚠ DANGER**

#### **Electrical Shock**

- Do not operate this generator if it is wet.
- Before performing any equipment check or maintenance, stop the engine and remove the engine key. The person performing the check or maintenance should always keep the key.

### **⚠ CAUTION**

#### **Injuries**

- Before performing any equipment check or maintenance, stop the engine and remove the engine key. The person performing the check or maintenance should always keep the key.

#### **Fire**

- The battery may emit highly explosive gases. Never expose it to flames or spark producing devices.
- Temperatures around the muffler and exhaust piping can get extremely high. Keep any flammable items (such as fuel, gas, paint, etc.) away from these areas.

Follow the guidelines below when performing any troubleshooting. If you cannot resolve the problem(s) by using this troubleshooting guide, contact the nearest authorized service center.

<b>Symptoms</b>	<b>Possible cause</b>	<b>Corrective Actions</b>
Starter motor will not turn over.	<ol style="list-style-type: none"> <li>1. Dead battery</li> <li>2. Weak battery</li> </ol>	<ol style="list-style-type: none"> <li>1. Replace the battery</li> <li>2. Recharge the battery</li> </ol>
Starter motor turns over but the engine will not start.	<ol style="list-style-type: none"> <li>1. Low fuel</li> <li>2. Water or contaminants in the fuel.</li> </ol>	<ol style="list-style-type: none"> <li>1. Refill the fuel tank</li> <li>2. Drain water or clean the fuel tank and fuel filter</li> </ol>
Engine starts, but stalls immediately.	<ol style="list-style-type: none"> <li>1. Low oil pressure</li> <li>2. High coolant temperature</li> <li>3. Air in the fuel system</li> </ol>	<ol style="list-style-type: none"> <li>1. Check the oil level and fill if necessary</li> <li>2. Check coolant level and fill if necessary</li> <li>3. Bleed out the air</li> </ol>
Cannot turn the circuit breaker to the ON position.	<ol style="list-style-type: none"> <li>1. Circuit breaker has not been completely turned to the OFF position</li> <li>2. Overload</li> </ol>	<ol style="list-style-type: none"> <li>1. Turn the circuit breaker to the OFF position</li> <li>2. Check the load side</li> </ol>
Black or white smoke is coming out of the exhaust line.	<ol style="list-style-type: none"> <li>1. Overloading</li> </ol>	<ol style="list-style-type: none"> <li>1. Reduce the load</li> </ol>

# **shindaiwa**

***Construction Products***

Shindaiwa Incorporated  
11975 SW Herman Road  
Tualatin, OR 97062  
Phone 503 692-3070  
Fax 503 692-6696

[www.kwietpower.com](http://www.kwietpower.com)

7/25/07 Part No. 80350

Manufactured by Shindaiwa Corporation  
Hiroshima, Japan